

Operating manual - **Archive document**

PTC thermistor relay type MS 220 VA and MSR 220 VA PTC-resistor trip device

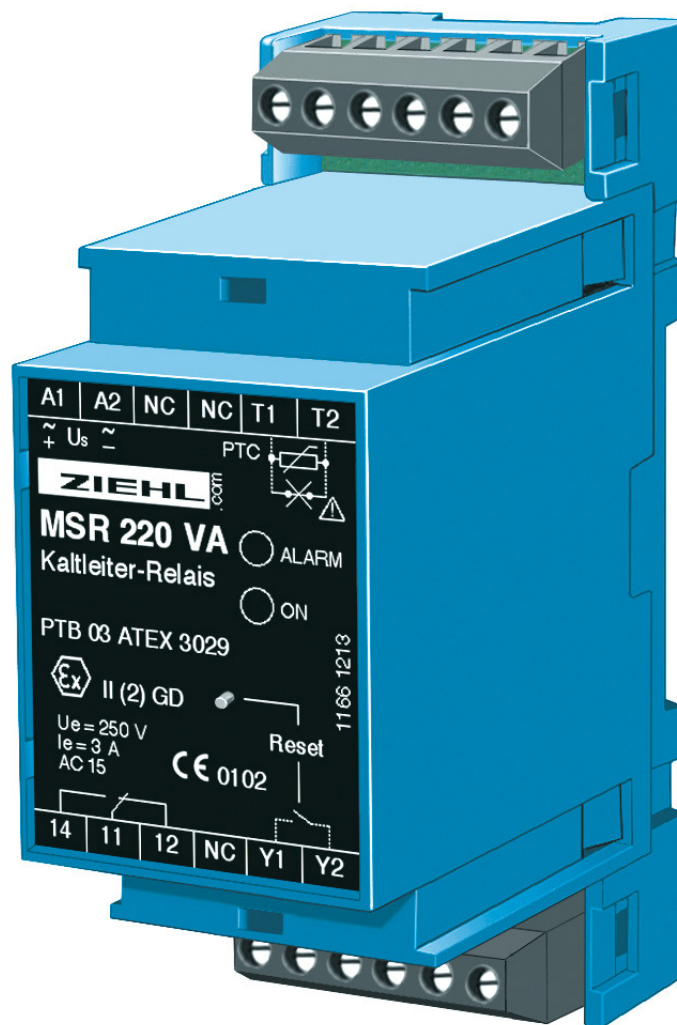

Application and Short description

ZIEHL PTC-resistor relays protect motors, transformers, machines and equipment against thermal overload. In combination with ZIEHL PTC Sensors MINIKA ® they offer best possible protection against thermal overload.

ZIEHL PTC-resistor relays are designed for PTC-sensors according to DIN 44081 and DIN 44082. These are according to DIN VDE 0660 chapter 303 and are thus exchangeable. PTC-resistor sensors are suitable for the installation into windings of electrical machines, bearings and transformers as well as to monitor the temperature of liquid media, airflow and gases.

Used in conjunction, they provide an effective and reliable protection in case of

- blocking rotors, heavy starts, countercurrent operation
- undervoltage and phase failure
- increased ambient temperature and hindered cooling

Approvals:

marking see type plate on the device

Wiring scheme

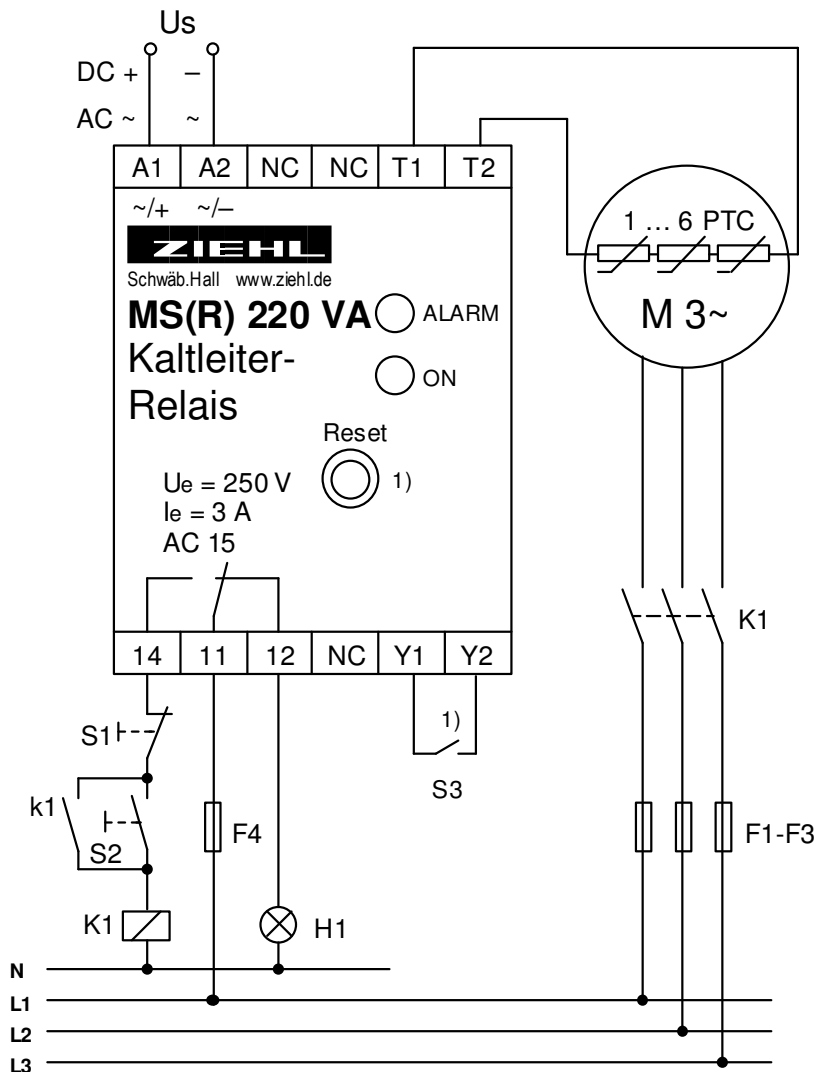

Us = supply voltage
 S1 = pushbutton off
 S2 = pushbutton on
 S3 = Reset external
 H1 = trip alarm
 F1-F4 = fuses
 K1 = contactor
 1) MSR only

Detailed description

All MS 220 and MSR 220 tripping devices work according to the closed-circuit principle. A current monitors continuously the resistance of the sensors. In cold state, the resistance is $< 250 \Omega$ per sensor (sensor circuit $< 1,5 \text{ k}\Omega$). The relay has picked up and contacts 11/14 are closed. The resistance of the sensor rises rapidly at nominal response temperature NRT. The relay release at a resistance of $3 \dots 4 \text{ k}\Omega$ and contacts 11/12 close. The devices also switch off in the case of sensor or line short-circuit ($< \text{approx. } 20\Omega$) or sensor or line interruption. MS types switch on automatically when the temperature has decreased approx. $5 \text{ }^\circ\text{C}$. MSR types with electronic reclosing lock store shutdown and require a RESET (push built-in button or external with terminals Y1/Y2 closed or by return of supply voltage). Storage is not non-volatile. With terminals Y1/Y2 bridged, the electronic reclosing lock is deactivated. Then the devices work like type MS.

Functional overview

MS 220 VA (auto reset)

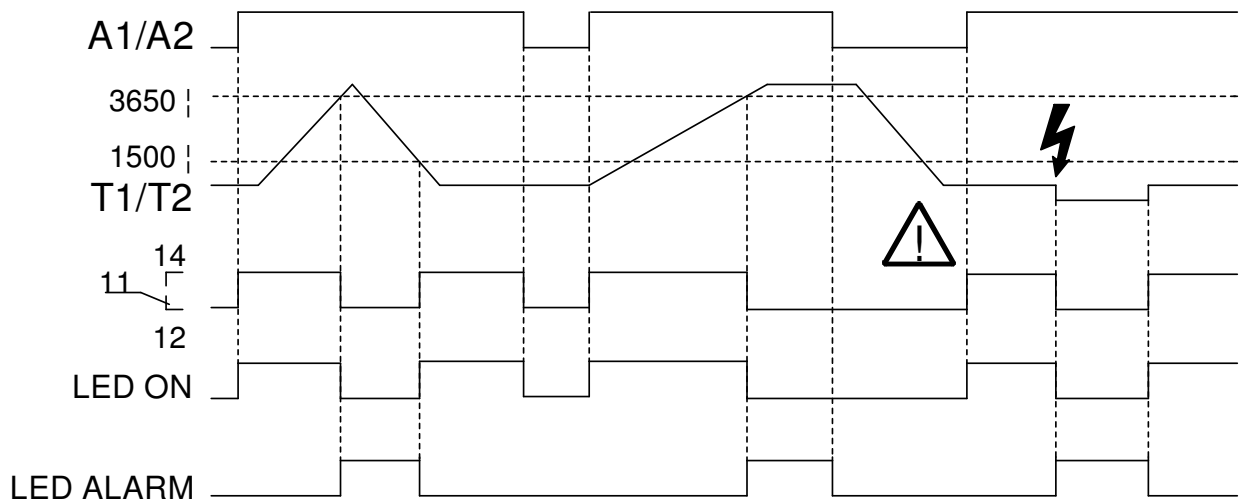

MSR 220 VA (electronic reclosing lock)

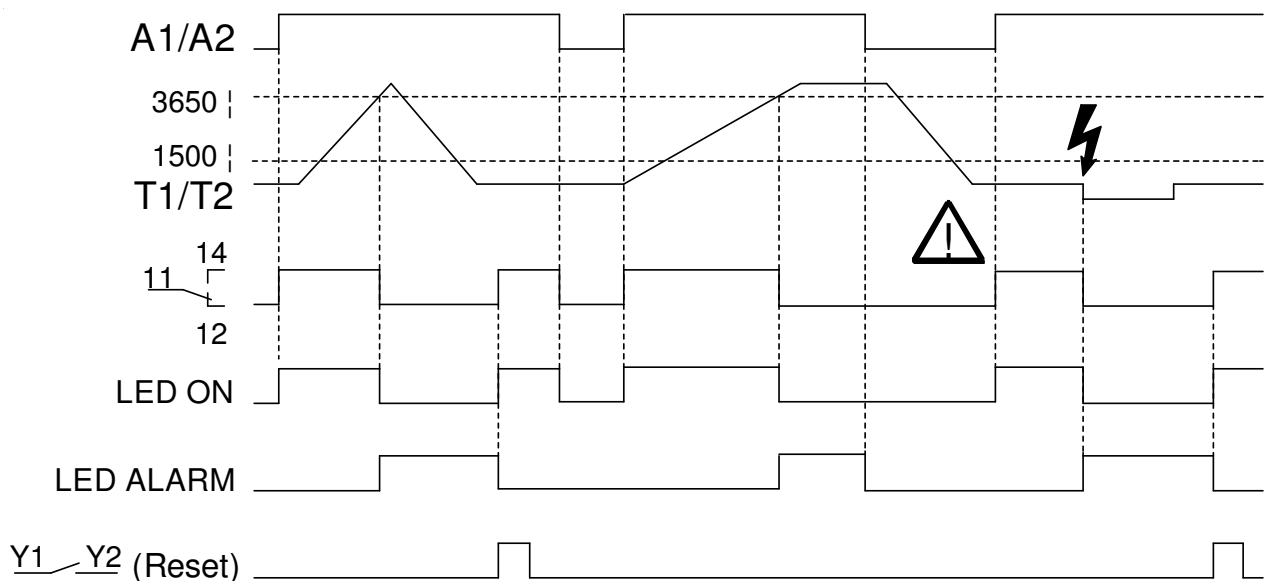

Important Notes/ Putting into operation



Warning !
observe safety rules and standards. Notice safety remarks!



Warning!
Before connecting the apparatus to the current, make sure, that the control voltage U_S written on the lateral type plate corresponds to the supply voltage.

- The device can be mounted on 35 mm standard rail EN 60715 or with screws of type M4
- The devices must be installed within rooms of international protection class IP 54 or better.

When installing the device into the switchgear cabinet, please observe the max. admissible temperature. Care for both, sufficient clearance to other devices or sources of heat or enough forced draught. If cooling is made more difficult, e.g. close devices with increased surface temperature or by handicap of airflow cooling, the permissible ambient temperature has to be reduced.

Trouble – shooting and remedies

Relay does not pick up. Please check

- The supply voltage U_s at terminals A1-A2. With ready for use equipment type MS the green LED lights.
- The PTC's at terminals T1-T2. In the case of disturbance the red LED lights.
- The resistance of a PTC circuit must be at $0 \Omega < R < 1500 \Omega$. The terminal voltage T1-T2 is to be $< 2,5 \text{ V}$ with connected PTC.
- With relay type MSR please push the Reset button. The relay can pick up at resistance $R < 1,65 \text{ k}\Omega$ and the RESET button changes from red to green. Alternatively reset can be done with closing an external contact at terminals Y1-Y2 or with power recovery.

Relay does not release. Please check

- With no PTC sensor connected the PTC Trip Relay must release. The voltage at terminals T1-T2 must be approx. 8 V. In case of any other malfunctions, replace device. Please add a description of the occurred malfunction when sending back for repair.

Technical Data

Power supply

Rated supply voltage U_s	AC 110-120 V, AC 220-240 V, AC 380-415 V (see type plate)
Tolerance voltage U_s	AC / DC 24 V (without potentially separation)
Frequency (AC)	AC 0,9 U_s -1,1 U_s DC 21 ... 30 V
Tolerance frequency	50 / 60 Hz
Power consumption	45 - 62 Hz
	$< 2 \text{ VA}$

Design V2

Dimensions in mm

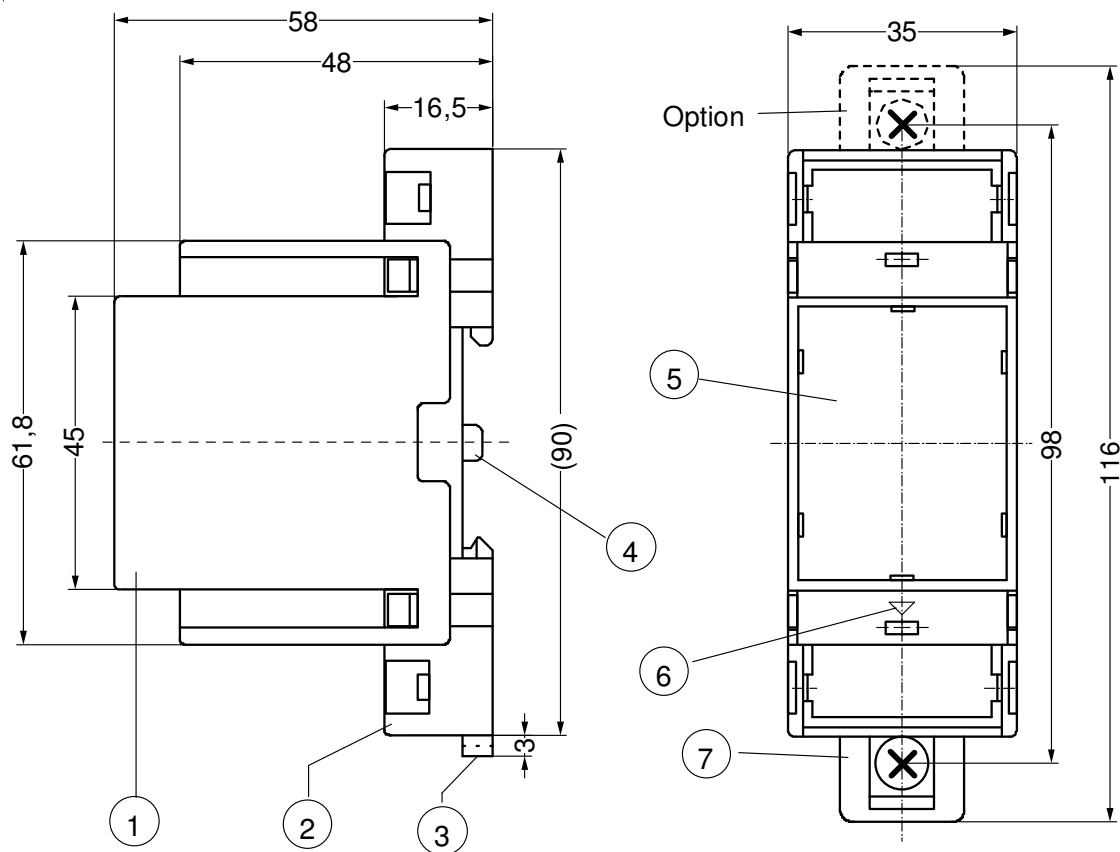

- 1 Oberteil / cover
- 2 Unterteil / base
- 3 Riegel / bar for snap mounting
- 4 Plombenlasche / latch for sealing
- 5 Frontplatteneinsatz / front panel
- 6 Kennzeichen für unten / position downward
- 7 Riegel bei Wandbefestigung mit Schrauben. Riegelbohrung \varnothing 4,2 mm / for fixing to wall with screws \varnothing 4,2 mm.



**Safety Instructions and references for putting into operation—
please read carefully!**

Special remarks for explosive gas atmospheres areas (Zone 1 and Zone 2)

- The increased danger within hazardous areas requires the careful attention of the safety instructions and references for putting into operation. Observe the national safety rules and regulations for prevention of accidents as well as the European Standard EN 60079-14 „Electrical apparatus for explosive gas atmospheres - Part 14: Electrical installations in hazardous areas (other than mines)“. Installation, electrical connection and commissioning to be carried out by trained service personnel only. Inappropriate behaviour can cause heavy personal damage and damages to property.
- The response of the thermal motor protection must directly switch off the motor, also when used together with converters. This must be realized in the logic section or configuration in the converter.

- The relay may be installed only outside potentially explosive atmospheres for the protection of explosive-protected motors. Within potentially explosive atmospheres the equipment is to be provided with a pressurized enclosure according EN 60079-2.

**Special remarks for use in the presence of combustible dust!
(Zone 21 and Zone 22)**

- The increased danger within hazardous areas of combustible dust requires the careful attention of the safety instructions and references for putting into operation. Observe the national safety rules and regulations for prevention of accidents as well as the European Standard EN 50281-1-2 „Electrical apparatus for use in the presence of combustible dust“. Installation, electrical connection and commissioning to be carried out by trained service personnel only. Inappropriate behaviour can cause heavy personal damage and damages to property.
- The relay may be installed only outside potentially explosive atmospheres for the protection of explosive-protected motors. Within potentially explosive atmospheres the equipment is to be provided with a dust proofed enclosure according EN 60529.

Special remarks for category 1 of EN 954-1.

Safety-related parts of category 1 must be arranged and built using proven constructions and proven safety principles. A loss of the safety function is possible in the case of an error.

Wiring.

- The lines of the sensor circuit are to be routed as separate control lines. The use of lines of the supply cable or other mainstream lines is not permissible. If extreme inductive or capacitive stray effects are to be expected by parallel cables of the power installation, shielded control lines should be used.
- With devices type MSR the terminals Y1, Y2 may be attached parallel to a common resetting mechanism. Sensor lines may not be connected together.

MS 220 VA und MSR 220 VA

- The line resistance within the sensor circuit may not exceed a value of 20 Ω.
- Maximum of permissible length for sensor circuit lines:

Leitungsquerschnitt Wire cross section	Leitungslänge Wire length
2,5 mm ²	2 x 1000 m
1,5 mm ²	2 x 800 m
1,0 mm ²	2 x 500 m
0,75 mm ²	2 x 300 m
0,5 mm ²	2 x 250 m

- With commissioning and after modification of the plant the sensor resistance must be checked with a suitable measuring instrument. With a resistance < 50 Ω the sensor circuit is to be examined for short-circuit.

Attention! Check PTC's only with measuring voltages of < 2.5 V.

Safe Separation

- Line circuits (A1, A2, 11,12,14) have a safe separation to low-voltage electric circuits (T1, T2, Y1, Y2).

- Trip relays with supply voltage DC/AC 24 V are permissible only at power supplies according EN 61558-2-6 where protected wiring is used.

Stop function, stop category 0

- A stop function released by the protection device must transfer the machine after manipulation of this function as fast as possible into a safe condition. The stop function must have top priority.
- In case of failure the relay switches off the contactor/circuit breaker and so prevents an overheating of the isolation system and/or the surface temperature. The protective function of the equipment is guaranteed only if wiring is done directly into the control circuit of the motor/machine in accordance with the connection diagram. The contacts must be protected, in order to prevent welding.

Start and Restart

- A restart may take place automatically only if no dangerous condition can be present. The tripping devices of types MS 220 are equipped with an automatic reset function. For this device design, suitable wiring of the control units must be ensured to prevent automatic restarting of the explosive-protected motor of the type of protection Increased Safety „e“ in case of failure.

Manual resetting

- After introducing a stop instruction by the protection device this must be maintained, until the manual resetting mechanism is operated and safe conditions for a renewed start are given. The manual resetting may be only possible, if all safety functions and protection devices are effective.
- Trip devices type MSR have an electronic reclosing lock. The stop instruction remains, until by pressing the push-button „Reset“ a reset is made. A start-up is only possible, if no case of failure occurs and the motor is cooled down to a sufficient value of temperature. Trip devices type MSR 220 switch on automatically with return of supply voltage. The user must guarantee by external interlock (see connection diagram) so the supervised motor/machine does not start again independently.

Special remarks for category 2 of EN 954-1.

The requirements of category 1 must be fulfilled. [The safety function must be tested once annually. The safety function must be tested within regular intervals. It is recommended to test once annually.](#) Depending on the zone risk, tests should be conducted more frequently. [Testing of the safety function is required at least with every start-up and before introducing dangerous conditions.](#) A fault is recognized by the safety test. A fault between safety tests can cause the loss of protection.

MS 220 VA und MSR 220 VA

- The safety function must be tested by interrupt the sensor circuit wire at terminals T1, T2
- The short circuit monitoring function must be tested by bridging the sensor circuit wires at terminals T1, T2
- With Trip relay type MSR the function of the electronic interlock must be tested additionally.
- If an error is detected no restart must be induced until the error is cleared.

Maintenance and repair

- The devices are maintenance-free. Only the manufacturer may accomplish repairs. EN 60079-17 [and/or EN 50281-1-2](#) are to be observed.