

Operating Manual UFR1001E

updated: 2015-11-20 Fu
from Firmware: 0-05

- NA-protection according to VDE-AR-N 4105, in-plant power generators on the low voltage grid
- For use in in-plant power generators on the medium voltage grid according to BDEW
- With selectable vector shift detection
- With selectable Rate of Change of Frequency (ROCOF, df/dt) protection



New, Firmware 0-05:

Default settings for Austria Pr_{10} , Great Britain Pr_{20} ... Pr_{23} and monitoring of 1 or 2 phases against N Pr_{7}

(Display of the firmware version: Inf_0 → Fnr or press "Set" for >10s)

1. Application and brief description	4
2. Summary of the functions	4
3. Display and controls	5
4. Detailed description	6
4.1 Description of the connections	6
4.2 Functional characteristics	6
5. Important information	7
6. Assembly	8
7. Connection diagrams	9
7.1 1x PV, 2x section switch (= Standard low voltage)	9
7.2 Multiple PV with section switch and with a series-switched NC's as feedback contacts ..	10
7.3 Multiple PV with section switch and with a parallel-switched closing contacts as feedback	11
7.4 1x PV, 1x section switch with nc/normally closed contacts (medium voltage)	12
7.5 Generator operation, suppression of the feedback contacts	13
8. Commissioning	14
8.1 Program setup	14
8.2 Control chart.....	15
8.3 Description of the parameters	17
8.4 Display mode (last decimal point off)	17
8.5 Menu mode (last decimal point on)	18
8.6 Configuration mode (last decimal point flashes)	18
8.7 Test mode (only activated and connected feedback contacts)	18
8.8 Alarm counter.....	18
8.9 Cumulative alarm time (display in hours)	18
8.10 Alarm memory.....	19
8.11 Standby counter and standby time.....	19
8.12 Code lock	20
8.13 Sealing	20
8.14 Simulation	21
8.15 Possible indications in display.....	22
9. Default settings and firmware version, VDE-AR-N 4105 + BDEW	23
9.1 Default settings and firmware version, ÖVE/ÖNORM E 8001-4-712, G83/2+G59/3	25
10. Technical Data	27
11. Maintenance and repair	28
12. Troubleshooting and measures	29
13. Construction form V6	30
14. Certificate of conformity VDE-AR-N 4105	31
15. Certificate of conformity bdew 2008 + 2013	33
16. Certificate of conformity ÖVE/ÖNORM E 8001-4-712, Pr 10	40
17. Certificate of conformity GB G59/3, Pr 20+21	41
18. Certificate of conformity GB G83/2, Pr 22+23	42

19. Certificate of conformity DIN V VDE V 0126-1-1, GB.....	43
20. Certificate of conformity DIN V VDE V 0126-1-1, Fr	44
21. Adjustment values table VDE-AR-N 4105, Low Voltage Pr 1+2+7	45
22. Adjustment values table BDEW June 2008, acc 3.2.3.3-1,Medium Voltage Pr 3-6	45

1. Application and brief description























The UFR1001E system-disconnection relay monitors voltage and frequency in three-phase current networks. It complies with the conditions for centralized NA-protection according to VDE-AR-N 4105 in in-plant power generators >30kVA, for feeding into the low voltage grid and the BDEW Directive for feeding into the medium voltage grid. When using with generators, the evaluation of feedback contacts for the period of a shut-down and during the synchronization can be suppressed.

The device has two channels which makes it more fail-safe. Input circuitry, evaluation and output relay are provided in duplicate. Two processors monitor each other mutually. Feedback contacts are used to monitor the functioning of both output relays and the section switch. During an alarm both channels shut down, the cause is displayed and it is reported through transistor outputs.





2. Summary of the functions

Applications include monitoring the network in generating plants such as solar and wind turbine generator systems along with mains protection in combined heat and power plants, also with synchronous generators (Vector surge).

The device complies with the requirements of the public utility power providers for conventional protection in low and medium voltage systems >30 kVA.

-  Under and overvoltage monitoring 40...520 V
-  Measurement 3 / 2 / 1 phases against N and/or phase-phase
-  Under and over frequency monitoring 45...65 Hz
-  Monitoring the voltage quality (10 minute average value)
-  Vector-surge monitoring 2...20° connectible
-  Fail-safe, with monitoring of the connected section switch (can be switched off), 2 automatic restarts on error
-  Passive autonomous system detection in accordance with Chapter 6.5.3 and Appendix D2
-  Monitoring of Rate of Change of Frequency (ROCOF, df/dt) connectible
-  Supports the mains synchronization when using generators
-  Self-test
-  Response time adjustable 0.05 ... 130.0 s, individual setting for each limit
-  Reset time adjustable 0 ... 999 s, individual setting for each limit
-  Reset time 5s at limit violation < 3s
-  Presetting per VDE-AR-N 4105, BDEW, ÖVE/ÖNORM E 8001-4-712, G83/2, G59/3
-  Alarm counter for 100 alarms (with trip value, cause and rel. time stamp)
-  Record of the cumulative time of alarms
-  Standby input with counter and time memory
-  Test button, simulation function, measurement of the shut-down times
-  LEDs for alarm signals, measurement value allocation and relay status
-  Sealing facility and code protection for settings, values can also be read in the sealed state
-  Simple commissioning and programming through 6 basic programs with preset limits
-  Message outputs for general alarm and for forwarding the cause of switching to the upstream controller (transistor, max. DC 27 V, 20 mA)

Medium voltage:

-  Per 2x2 limits for voltage and frequency: U<<, U<, U>, U>>, F<<, F<, F>, F>>
-  Hysteresis, response and reset value individually adjustable
-  Control voltage AC/DC 24-270 V
-  Distributor housing V6, 6 TE 105 mm wide, front-to-back size 55 mm

3. Display and controls

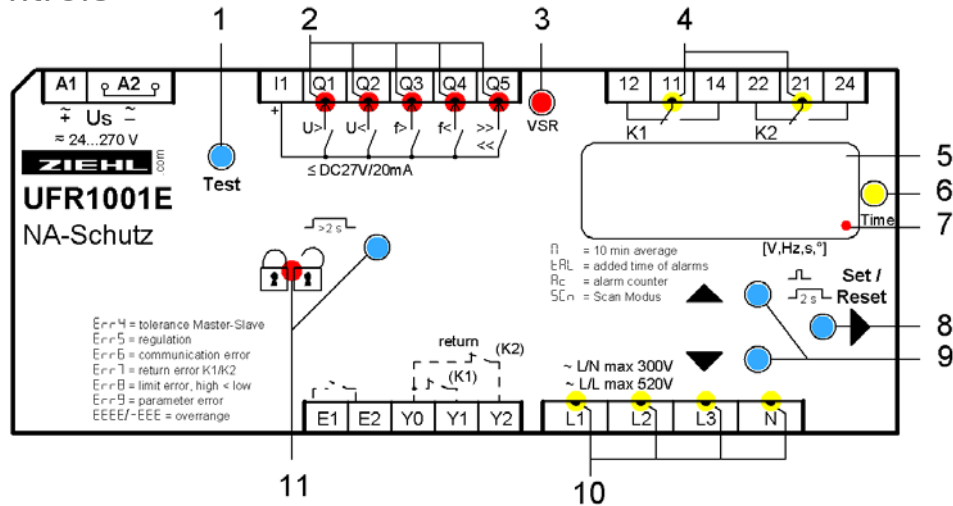

1 Test button

Press briefly	Output relays de-energize immediately. If Y1+Y2 are connected and the feedback signal is activated, the tripping time is displayed until the next time a button is pressed
---------------	--

2 LEDs frequency / voltage limit value undercut / exceeded (red)

On, RL or RL Π	Limit value undercut / exceeded
FLASHES, RL or RL Π	Reset delay Δt counting down

3 LED vector surge (VSR, red)

ON, RL	Threshold value for vector shift exceeded
FLASHES, RL	Reset delay Δt counting down

4 LEDs relay status (yellow)

OFF	Relay is released
ON	Relay operating

5 Digital display 4-digits (red)

Depending on program, display of current voltage, frequency, vector shift, average value
Displays the alarm signals, e.g. RL, RL Π
Displays the errors with error code e.g. Err 9

6 LED Time (yellow)

ON	A time is displayed
----	---------------------

7 Last decimal point (red)

OFF	Display mode
Illuminated	Menu mode
Flashes	Configuration mode

8 Set/Reset key (in display mode, normal state)

Press briefly	Display of next measured value / alarm counter
Press for > 2 s	Reset, quit error messages
Press for > 4 s	Displays the program, e.g. Pr 1
Press for > 10 s	Displays the software version, e.g. 0-05

9 Up / Down key (in display mode, normal state)

Press briefly	Change to the menu mode, display of alarm memory (Down) / cumulative time of alarms, standby counter, standby time (Up), pushing Set button for ≥ 2 s resets the stored values
Press for > 2 s	Display of MAX (Up) / MIN (Down) - measured values, additional pushing of Set button for ≥ 2 s deletes the stored values

10 LEDs measurement allocation (yellow)

LEDs	Measured value
Lx and N ON	Voltage value (L1 against N, L2 against N, L3 against N)
Lx and Ly ON	Voltage value (L1 against L2, L2 against L3, L1 against L3)
Lx FLASHING quickly	Vector surge (L1, L2, L3)
L1 FLASHING	Frequency

11 Sealable button + LED

Press for > 2 s	Lock / Unlock
 LED red	Settings and simulation mode are locked, While attempting to set, Loc is displayed for 3s
LED green	Setting and simulation enabled

4. Detailed description

4.1 Description of the connections

Connection	Description
A1 and A2	Rated control supply voltage U_s , see Technical Data
11, 12, 14; 21, 22, 24	Relay K1 and K2
E1 – E2 Enable – Input	Volt-free contact
	u5r . → oFF . , no function
	u5r . → oN . , E1-E2 closed: Vector shift active but not evaluated, monitoring of feedback contacts off for use with generator (mains synchronization)
	u5r . → 5tby . , E1-E2 closed: K1 and K2 off (standby), vector shift off
Y0, Y1, Y2 Inputs, feedback contacts	Volt-free n/o or n/c contact, self-learning when switching on
	Set value > turn-on time section switch under rEL . → ErEL . / can switch-off if not connected or if external devices/switches can activate the section switch (oFF .)
I1	Supply voltage for digital outputs, max. 27 V DC
Q1...Q4	Digital output over-/under voltage/-frequency, Q3 + Q4 = ROCOF
Q5	Digital output error, in Programs with >> and << additionally the 2nd threshold value
L1, L2, L3, N	Phase L1, L2, L3 and neutral conductor

4.2 Functional characteristics

Functional characteristics	Explanation
VSR display value	The highest measured value is always displayed. The display value is reset to 0 by deleting the max. value and when resetting into the go (good) state.
Delay Enable On time	Runs down when starting the unit and after opening the enable input; during this time there is no evaluation of the vector shift
Reset time	When a reset time doF is running, it is always counted down in the display (shortest one first)
Reset	Use the Reset key or interrupt the control voltage for > 2 s (comply with reset delay)
Display mode Scn	After the last measurement it switches into the scan mode; this is indicated by the display 5cn . All measurements will now be displayed cyclically for the time set in dt .
MIN / MAX values	All min and max values are saved zero-voltage maintained (non-volatile).

Tripping time (only with feedback contacts connected)	Connecting the feedback contacts enables measuring the shut-down time. After a tripping time with the test button it is displayed until a button is pressed again with a resolution of up to 1ms. Total shut-down time = Tripping time + Response time dRL . After a shut-down in the simulation mode the total shut-down time is displayed until the button is pressed again) The longer time of both channels is always displayed.
Alarm counter	The unit saves max 100 alarms (cause, measurement value, at operating time). The LEDs indicate the cause; the tripping value that led to the alarm each stands in the 7-segment display. Alternately the time difference, current operating time – tripping operating time is displayed. (how long ago the alarm triggered)
Cumulative alarm time tRL	The cumulative alarm time TAL indicates how long the relay was switched off due to an alarm. It is recorded with a resolution of 1 minute and only when the control voltage is applied. Query: In the display mode ▶ button to Rc is displayed. 1x ▲ button = Cumulative alarm time tRL
Standby mode u5r → 5tbY	If E1-E2 are closed (e.g., by ripple control receiver, timer, dimmer), Relays K1 and K2 are switched off. The number and duration of the shut-downs is recorded. Query: In the display mode ▶ button to Rc is displayed. 2x ▲ button = Standby counter 5tbY . 1x ▲ button = Standby time 5tbY
Standby mode u5r → Y 192	If E1-E2 are closed, the evaluation of the feedback contacts is suppressed. That means when using generators, a section switch can be used for mains synchronization.
Automatic restart attempts	If there is an error by the feedback contacts Err1 , 2 restart attempts are automatically performed in an interval of 10s. False triggering by undervoltage trips (e.g. during a thunderstorm) do not lead to permanent shut-down.

5. Important information



A marked switch and a protective device must be provided in the supply line in the vicinity of the device (easily accessible) as a disconnecting element
(rated current ≤ 6A).

Flawless and safe operation of such a device requires proper transport and storage, professional installation and later commissioning along with operation as intended.

Only persons who are familiar with the installation, commissioning and operation of the device and who are correspondingly qualified for their job are permitted to work on the device. They must comply with the contents of the operating manual, the instructions attached to the device and the pertinent safety regulations for the erection and operation of electrical equipment.

The devices are built and certified in accordance with EN 60255 and leave the factory in a safe and technically flawless condition. To maintain this condition they must comply with the safety regulations marked in the operating manual with the headline "Caution". Failure to follow the safety regulations can lead to death, bodily injury or property damage to the device itself and to other devices and equipment. If the information contained in the operating instructions/operating manual are not sufficient, please contact us directly or contact your responsible agency or representative.

Instead of the industrial norms and stipulations stated in the operating manual and applicable in Europe you must comply with the valid and applicable regulations in the country of utilisation if the device is used outside of the area of application.



WARNING

Hazards electrical voltage!

Can lead to an electric shock and burns.

Disconnect and de-energize before working on the system and the device.

6. Assembly

The device can be mounted:

 Distribution panel or control panel on 35 mm rail according to EN 60715

Comply with the maximum permissible temperature when installing in a switch cabinet. Ensure sufficient clearance to other devices or heat sources. If cooling is inhibited, e.g., through close proximity to devices with increased surface temperature or interference with the cooling-air current, the permissible ambient temperature is decreased.



Caution!

Before you apply mains voltage to the device, make sure that the permissible control voltage **Us** on the side rating plate matches the mains voltage connected to the device!

7. Connection diagrams

7.1 1x PV, 2x section switch (= Standard low voltage)

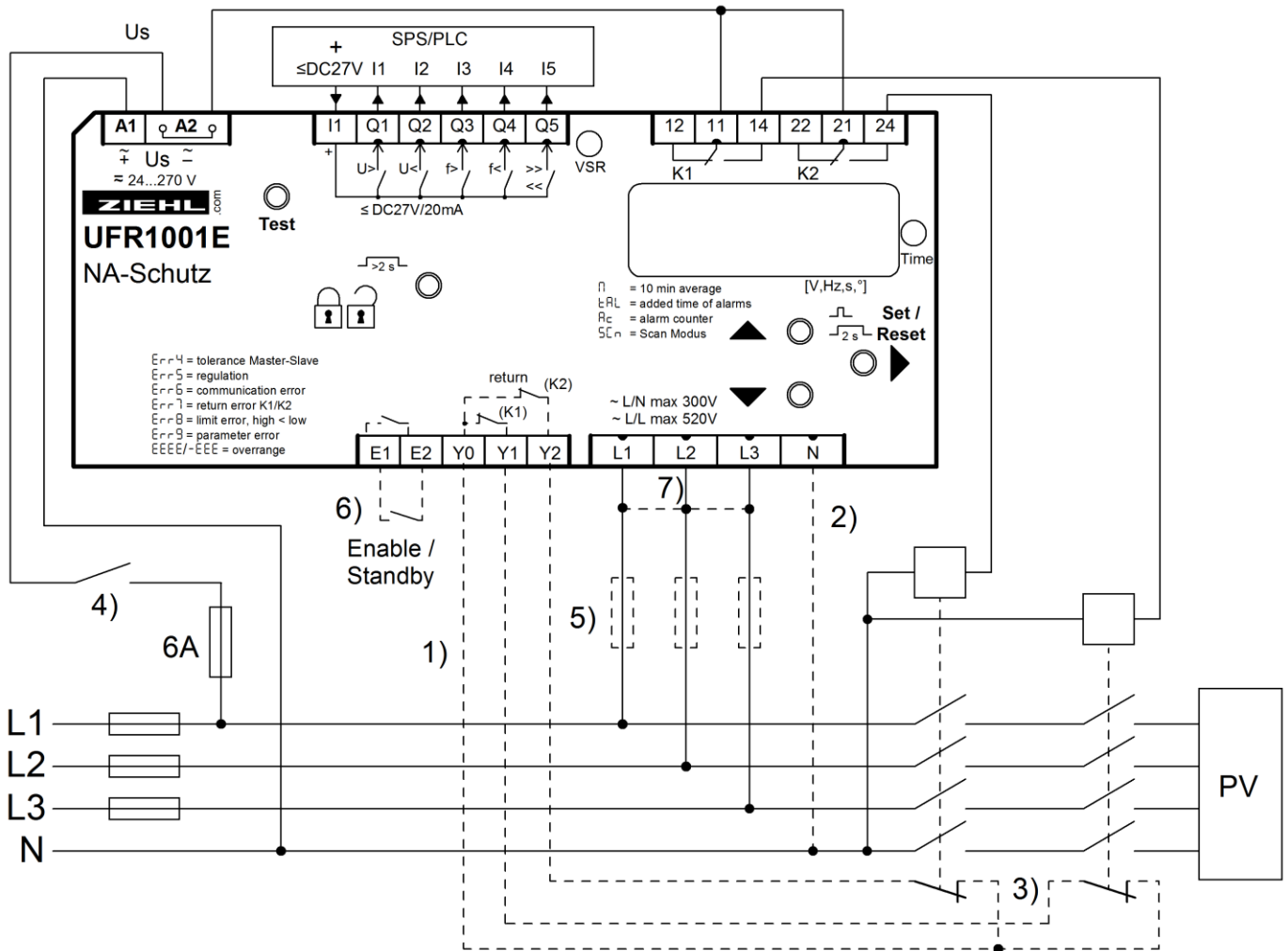

- 1) Feedback contacts not connected set rEL → $t rEL$ → **OFF**.
- 2) N connected set $Pr 1$, $Pr 3$ or $Pr 5$
- 3) Nc- or no-contacts can be connected, automatic detection when switching on
- 4) Switch off the plant without recording an alarm, e.g. with output contact of a ripple control receiver
- 5) Fuses only when line protection necessary, e.g. 3x16A
- 6) Contact closed suppresses evaluation of feedback contacts and vector shift ($u5r$ → **ON**) suppresses feedback contacts ($u5r$ → **Y1Y2**) or switches device into standby ($u5r$ → **StBY** = default setting) e.g. through ripple control receiver or timer
- 7) 1 phase Application connect L1-L2-L3, 2 phase Application L1 / L2+L3 (only Pr 5, 7, 10, 20)

7.2 Multiple PV with section switch and with a series-switched NC's as feedback contacts (expanded inventory plant)

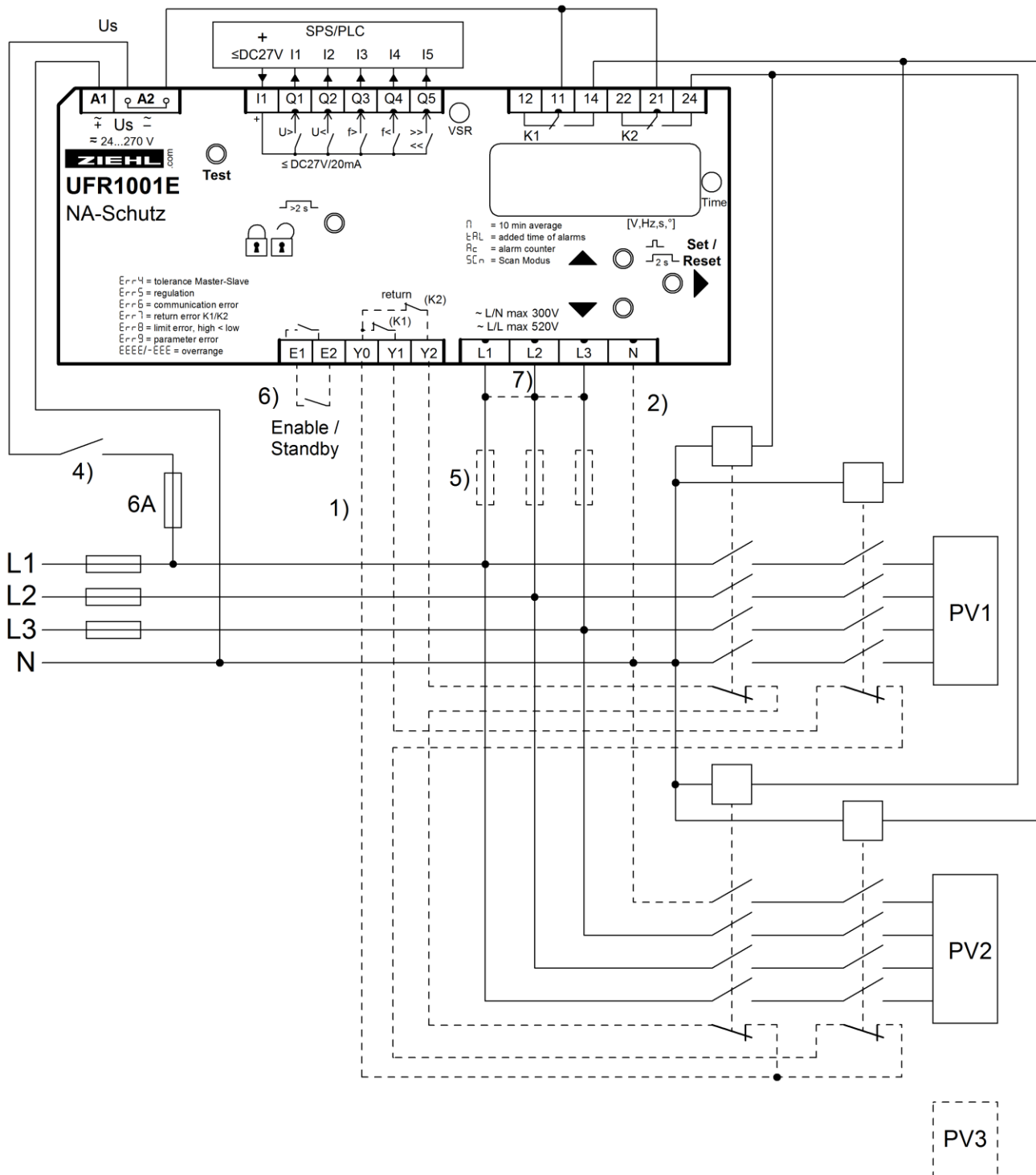

- 1) Contactor feedback contacts not connected set r_{EL} → t_{rEL} → **OFF**.
- 2) N connected set $Pr 1$, $Pr 3$ or $Pr 5$
- 4) Switch off the plant without recording an alarm, e.g. with output contact of a ripple control receiver
- 5) Fuses only when line protection necessary, e.g. 3x16A
- 6) Contact closed suppresses evaluation of feedback contacts and vector shift
(u_{sr} → **on**) suppresses feedback contacts (u_{sr} → **Y1Y2**) or switches device into standby (u_{sr} → **StBY** = default setting) e.g. through ripple control receiver or timer
- 7) 1 phase Application connect L1-L2-L3, 2 phase Application L1 / L2+L3 (only Pr 5, 7, 10, 20)

7.3 Multiple PV with section switch and with a parallel-switched closing contacts as feedback (expanded inventory plant)

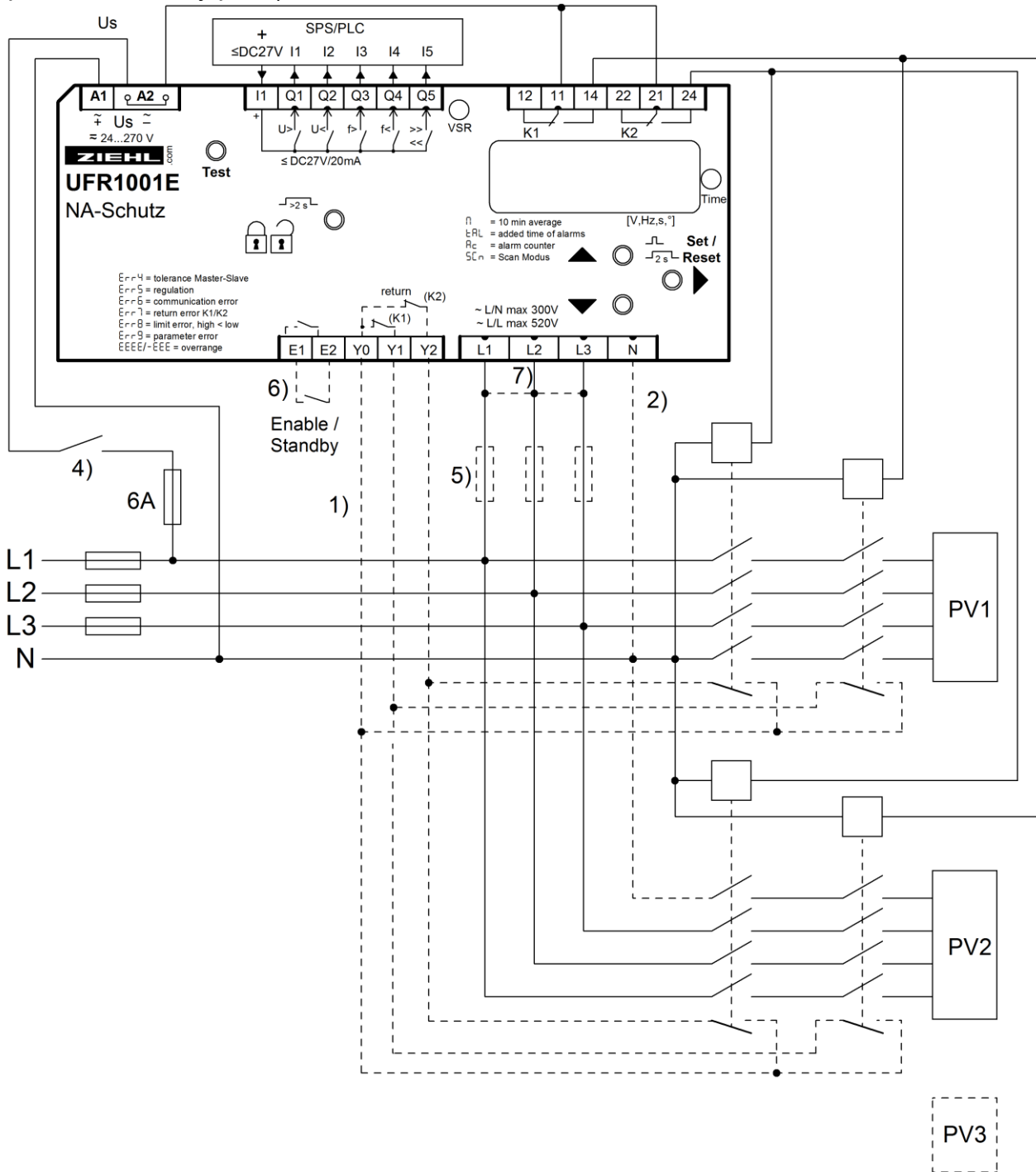

- 1) Feedback contacts not connected set $r_{EL} \rightarrow t_{rEL} \rightarrow \text{OFF}$.
- 2) N connected set $Pr 1$, $Pr 3$ or $Pr 5$
- 4) Switch off the plant without recording an alarm, e.g. with output contact of a ripple control receiver
- 5) Fuses only when line protection necessary, e.g. 3x16A
- 6) Contact closed suppresses evaluation of feedback contacts and vector shift
 $(u_{Sr} \rightarrow \text{on})$ suppresses feedback contacts $(u_{Sr} \rightarrow Y1Y2)$ or switches device into standby $(u_{Sr} \rightarrow \text{Stby})$ = default setting) e.g. through ripple control receiver or timer
- 7) 1 phase Application connect L1-L2-L3, 2 phase Application L1 / L2+L3 (only Pr 5, 7, 10, 20)

7.4 1x PV, 1x section switch with nc/normally closed contacts (medium voltage)

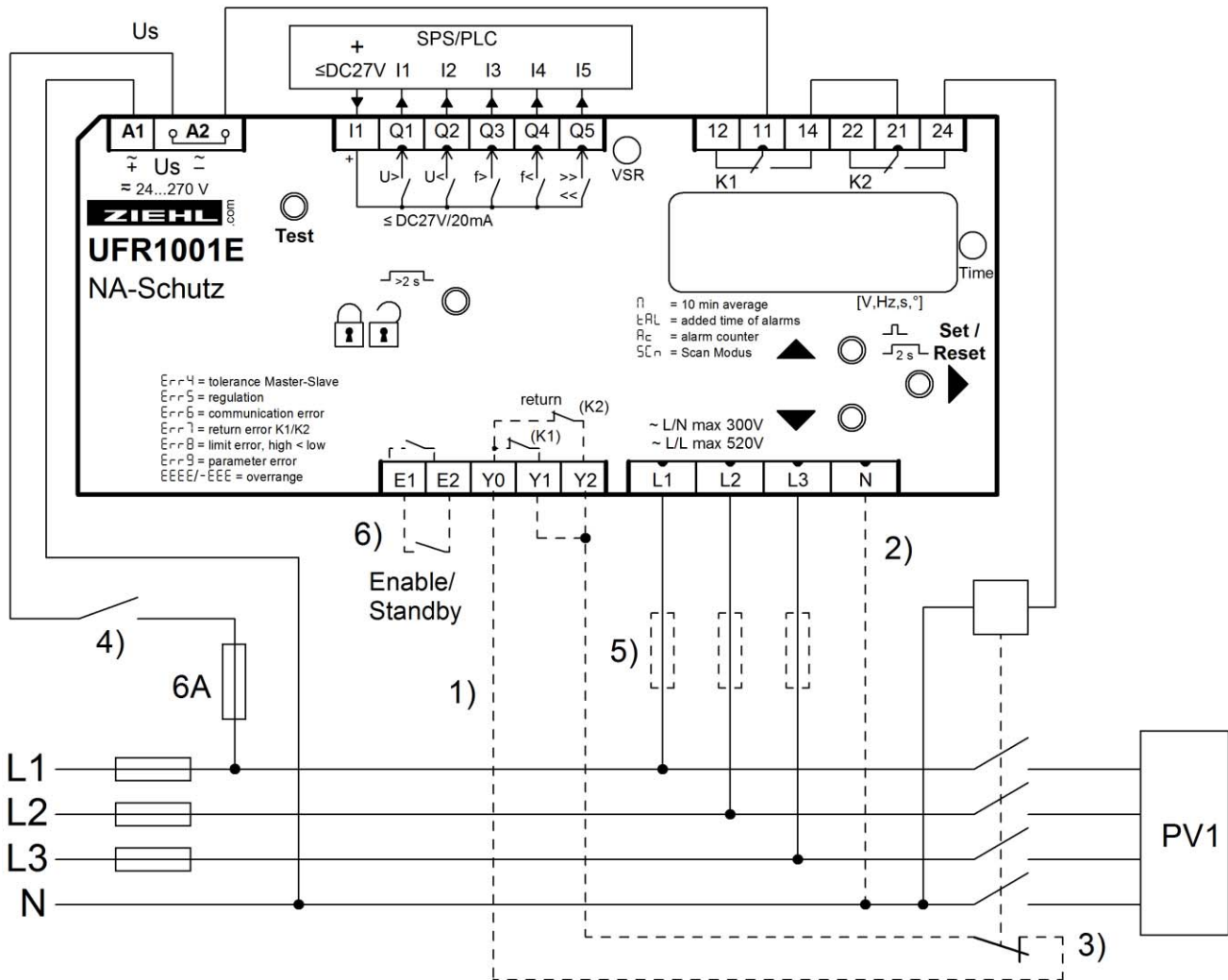

- 1) Feedback contacts not connected set rEL → t_rEL → OFF.
- 2) N connected set $Pr1$, $Pr3$ or $Pr5$
- 3) Nc- or no-contacts can be connected, automatic detection when switching on
- 4) Switch off the plant without recording an alarm, e.g. with output contact of a ripple control receiver
- 5) Fuses only when line protection necessary, e.g. 3x16A
- 6) Contact closed suppresses evaluation of feedback contacts and vector shift ($u_{5r} \rightarrow on$) suppresses feedback contacts ($u_{5r} \rightarrow Y1Y2$) or switches device into standby ($u_{5r} \rightarrow Stby$ = default setting) e.g. through ripple control receiver or timer

7.5 Generator operation, suppression of the feedback contacts (with external shut-down and mains synchronization)

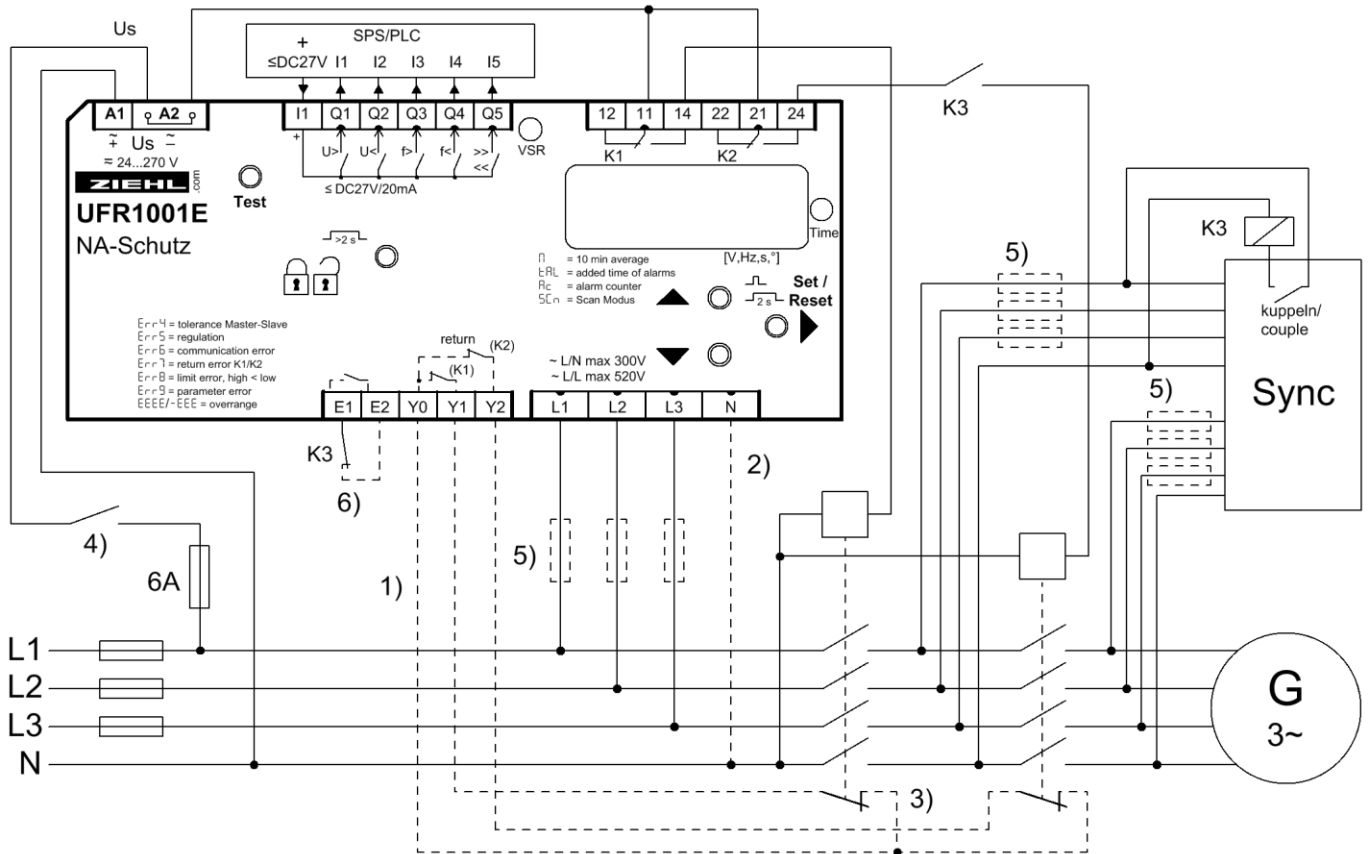





- 1) Feedback contacts not connected set rEL → t_rEL → **OFF**.
- 2) N connected set $Pr 1$, $Pr 3$ or $Pr 5$
- 3) Nc- or no-contacts can be connected, automatic detection when switching on
- 4) Switch off the plant without recording an alarm, e.g. with output contact of a ripple control receiver
- 5) Fuses only when line protection necessary, e.g. 3x16A
- 6) Contact closed suppresses evaluation of feedback contacts and vector shift
($u5r$ → **on**) suppresses feedback contacts ($u5r$ → **Y1Y2**) or switches device into standby ($u5r$ → **StBY** = default setting) e.g. through ripple control receiver or timer

8. Commissioning

8.1 Program setup





The suitable program must be set on the UFR1001E in accordance with the application. If the UFR1001E is sealed/locked (red LED illuminated), the sealing has to be deactivated first.

Pr	Connection	Threshold Values	Voltage	Country / Standard
*1	3 AC with N	<u>Low voltage</u> 1x over voltage, 1x under voltage	230V	 VDE-AR-N 4105
2	3 AC without N	1x over frequency, 1x under frequency	400V	
7	2/1 AC with N	10 min average value, 1x vector shift 1x ROCOF	230V	
3	3 AC with N	<u>Medium voltage</u>	57,7V	 BDEW Juni 2008 nach 3.2.3.3-1
4	3 AC without N	2x over voltage, 2x under voltage	100V	
5	3/2/1 AC with N	2x over frequency, 2x under frequency 10min mean value, 1x vector shift	230V	
6	3 AC without N	1x ROCOF	400V	
10	3/2/1 AC with N	1x overvoltage, 1x under voltage 1x over frequency, 1x under frequency 10 min average value, 1x vector shift 1x ROCOF	230V	 ÖVE/ÖNORM E 8001-4-712
20	3/2/1 AC with N	2x over voltage, 2x under voltage	230V	 G83/2 + G59/3
21	3 AC without N	2x over frequency, 2x under frequency 10min mean value, 1x vector shift	400V	
22	3 AC with N	1x ROCOF	57,7V	
23	3 AC without N		100V	







* default setting

Adjustment process:

If present, remove seal (only authorised person)

 Apply control supply voltage at A1-A2
 Slightly lift the key cover and turn 180°
 Actuate the small blue button by firmly pressing the button cover (LED starts flashing) until the green LED  is illuminated.

Sealing is deactivated

 Press ▲ button 1x → display l nF a.
 Press ► button 5x → display Pr l.
 Set the program with the buttons ▲ ▼
 Press ► button 1x → display no.
 Press ▼ button 1x → display YES.
 Press ► button
 Device resets and starts with the newly selected program

Hint: When changing programs, all parameters of the selected program are reset to “default settings” (see table „Default settings“). **Only change the parameters after having selected the correct program.**

8.2 Control chart

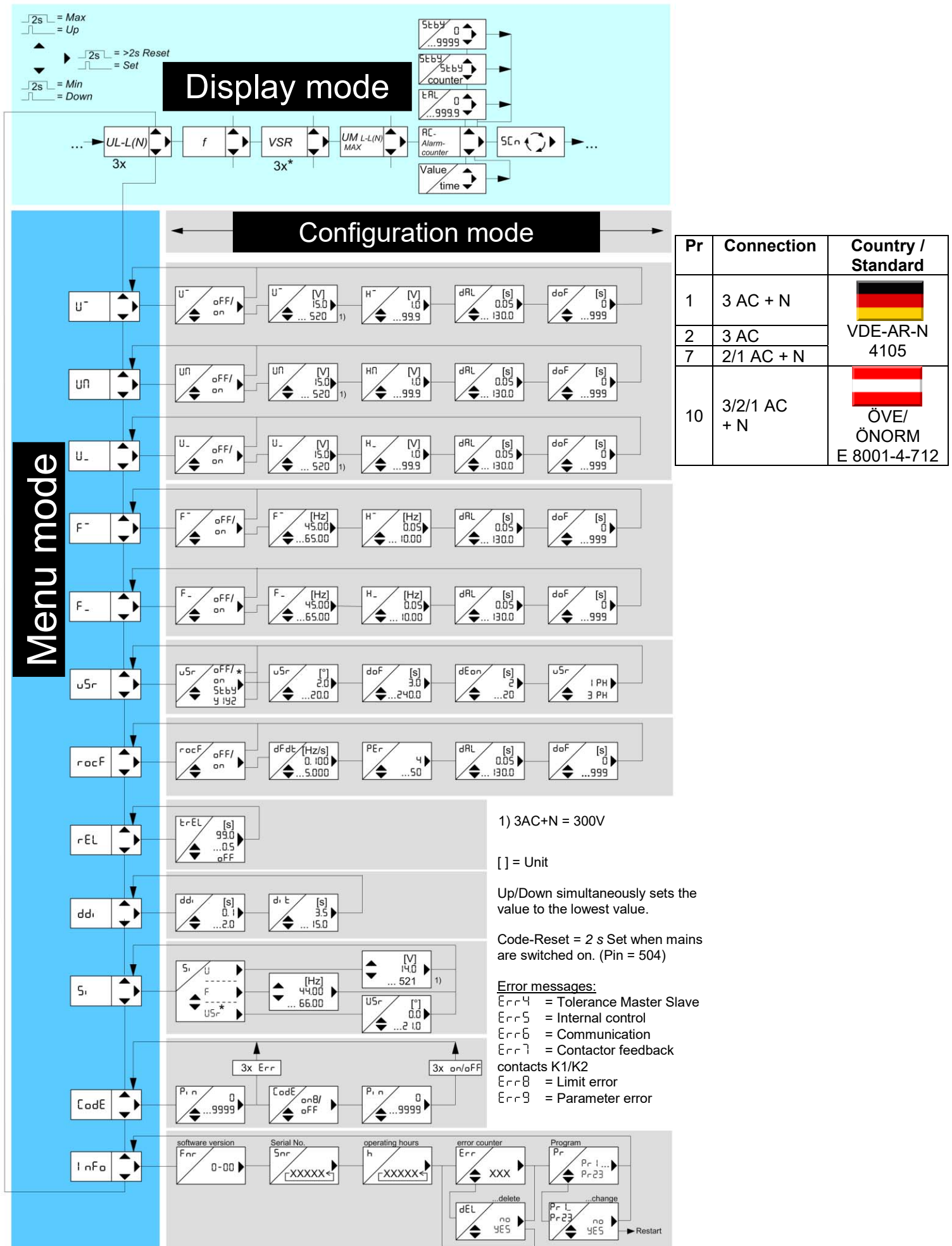

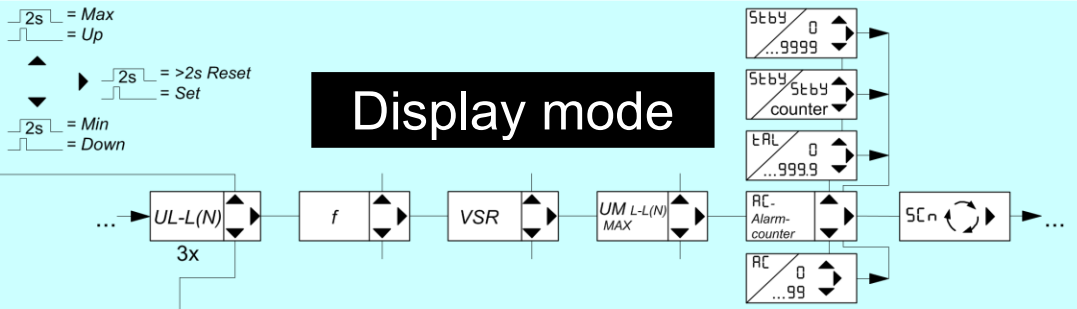

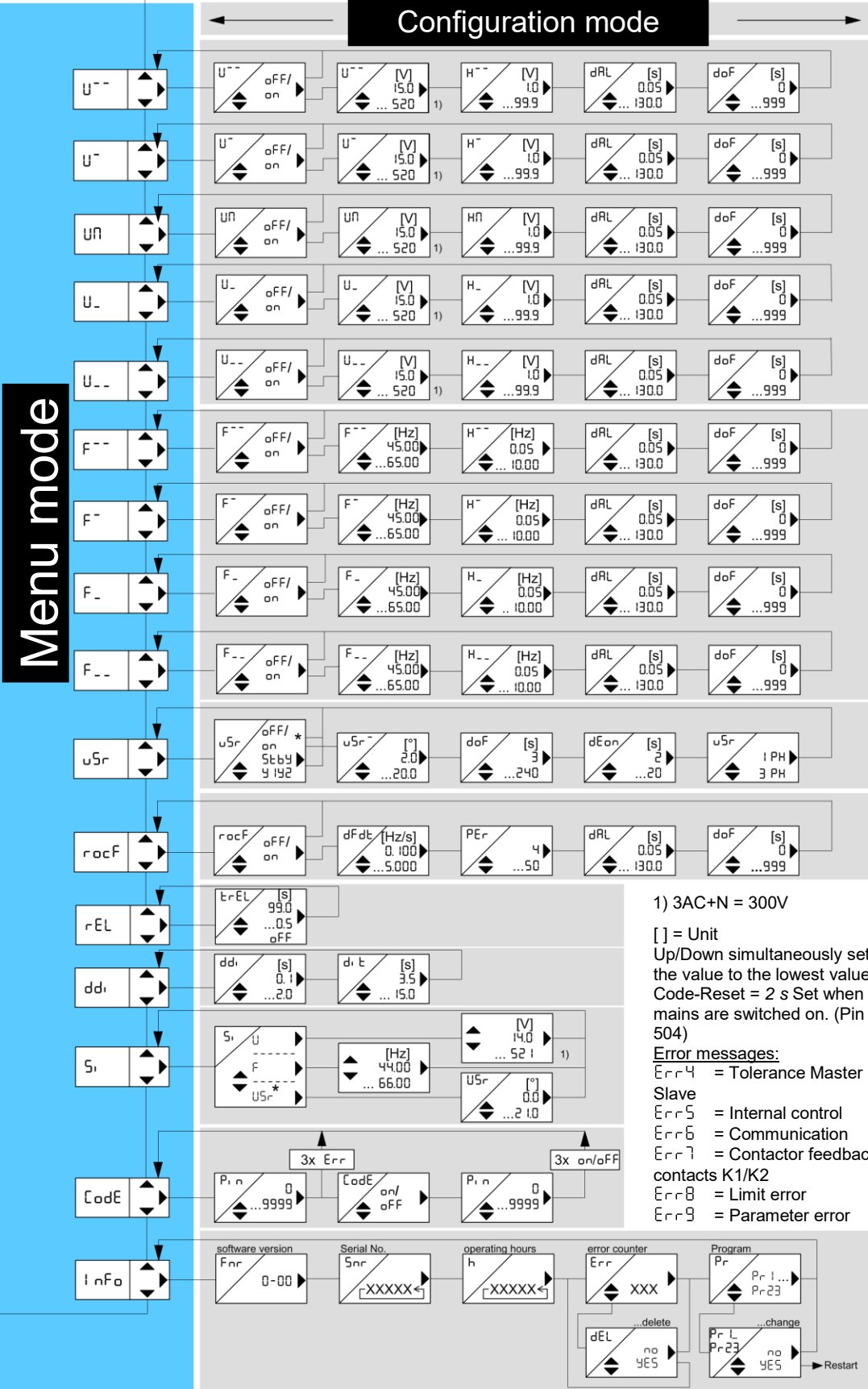

Display mode



Menu mode

Pr	Connection	Country / Standard
3	3 AC + N	 BDEW Juni 2008 nach 3.2.3.3-1
4	3 AC	
5	3/2/1 AC + N	
6	3 AC	 G83/2 + G59/3
20	3/2/1 AC + N	
21	3 AC	
22	3 AC + N	
23	3 AC	

1) 3AC+N = 300V
 [] = Unit
 Up/Down simultaneously sets the value to the lowest value.
 Code-Reset = 2 s Set when mains are switched on. (Pin = 504)
Error messages:
 Err4 = Tolerance Master
 Slave
 Err5 = Internal control
 Err6 = Communication
 Err7 = Contactor feedback contacts K1/K2
 Err8 = Limit error
 Err9 = Parameter error

8.3 Description of the parameters

Parameters	Display	Explanation	Adjustment range
Limit value	U ⁻⁻⁻ U ⁻ U ₋ U ₋₋ UN	Voltage limit value	15.0 ... 300 15.0 ... 520
Limit value	F ⁻⁻⁻ F ⁻ F ₋ F ₋₋	Frequency limit value	45.00 ... 65.00
Limit value	dFdt	ROCOF, df/dt limit value	0.10 ... 5.00
Hysteresis	H	253V (Limit) – 3V (Hysteresis) = 250V (Reset value) If the limit value is offset at F ⁻ , the hysteresis also has to be adapted so that the reset point lies at 50.05 Hz again.	1.0 ... 99.0 0.05 ... 10.00
Response time (delay Alarm)	dAL	An alarm is suppressed for the set time (seconds)	0.05 ... 130.0
Turn-on time (delay Off)	doF	Reset is delayed for the set time, also during voltage recovery, this time (seconds) is always counted down in the display	0 ... 999
Enable time (delay On)	dEon	There is no evaluation of the vector shift during this time; starts with the application of the control voltage and when opening the Enable input	2 ... 20
VSR	uSr	1 Ph : a vector surge on one phase leads to an alarm 3 Ph : a vector surge on all phases simultaneously leads to an alarm	1 Ph ... 3 Ph
Periods	PEr	Measuring time ROCOF, (4=sensitive, 50=insensitive) Response time= PEr * Period duration + dAL	4 ... 50
delay Display	ddi	Interval during which the display is updated in the display mode,	0.1 ... 2.0

8.4 Display mode (last decimal point off)

In the display mode, the UFR1001E is in its normal state; here, depending on the program, the actual voltage, the highest actual 10 minute mean value, the frequency or the vector surge is displayed. In addition, the alarm signals (e.g. AL, AL Π) and error codes (e.g. Err9) are displayed.

Function button Set / Reset	Press briefly: Switches the measurement, alarm counter
	Press for > 2 s: Resets after locked alarm (not possible if doF Reset delay is counting down)
	Press for > 4 s: Displays the program, e.g. Pr 1
	Press for > 10 s: Displays the software version, e.g. 0-05
Function key	Press briefly: Change into the menu mode,

Up / Down	Display alarm counter: Down = Query the memory Up = Query the cumulative alarm time
	<u>Press for ≥ 2 s:</u> Displays MAX and MIN measurements, additionally pressing the Set key for ≥ 2 s deletes the saved values

8.5 Menu mode (last decimal point on)

The menu mode is used to select the menu items. If no key is pressed for 30 s, one automatically returns to the display mode.

Function button Set / Reset	<u>Press briefly:</u> Change into the configuration mode
	<u>Press for ≥ 2 s:</u> Returns to the display mode (the most recently set values are then applied)
Function key Up / Down	<u>Press briefly:</u> Select menu item; changes into the display mode

8.6 Configuration mode (last decimal point flashes)

In the configuration mode you can set the value of a parameter. The display alternates between the parameter relation and the currently set value until one of the Up/Down buttons is pressed, which changes the value of the parameter. If no key is pressed for 2 s the display starts alternating again. If no key is pressed for 30 s (simulation mode 15 min) one automatically returns to the display mode (the most recently set value is applied during this)

Function button Set / Reset	<u>Press briefly:</u> The settings are taken over; continue to next parameter. Changes into menu mode after the last parameter
	<u>Press for ≥ 2 s:</u> Returns to the display mode (the most recently set values are then applied)
Function key Up / Down	<u>Press briefly/long:</u> Value change of the parameter (slow/fast)

Hint: Simultaneously pressing the Up and Down keys resets the adjustable value to zero. If the Up or Down button is kept pressed while setting the value the change in the display is accelerated.



8.7 Test mode (only activated and connected feedback contacts)

If feedback contacts of the section switch are connected to the UFR1001E and activated (value > set turn-on time of section switch, e.g. 5.0s), the trip circuit can be tested by pressing the Test button. To do that, the measurement voltage has to be connected and no alarm is allowed to be present! After pressing the Test button the UFR1001E triggers. The tripping time of the internal relay + section switch are measured through the feedback contacts. After successful tripping, the tripping time of the slower switch remains shown in the display until any key is pressed.

8.8 Alarm counter

The alarm counter **R_c** is increased by 1 with every shut-down. Up to 100 shut-downs are counted. That allows quick detection of how often the UFR1001E has shut down since the last delete of the alarm counter (see cumulative alarm time).

Query the alarm counter:





 Change into the display mode
 Press the  button several times until → display R_cxx

8.9 Cumulative alarm time (display in hours)



The cumulative alarm time **t_{RL}** indicates how long the relay was switched off due to an alarm. It is recorded with a resolution of 1 minute and only when the control voltage is applied.

Query the cumulative alarm time:

 Change into the display mode
--

 Press the  button several times until → display Rcxx
 Press the  button 1x → display tAL / x.xx







Delete the alarm counter and cumulative alarm time (only together):

 Display alarm counter Rcxx
 Press the  button 1x → display tAL / x.xx
 Keep the  button pressed for 2s until → display tAL / 0.00

8.10 Alarm memory

Independent of the alarm counter, the UFR1001E stores the most recent 100 shut-down causes (cause, measurement value, at operating time). Simulated alarms are also registered. The LEDs indicate the cause; the tripping value that led to the alarm each stands in the 7-segment display. Alternative to that the time is shown in hours which have passed since the last tripping (with applied control voltage). These values remain saved even after the power has been turned off.

Query alarm memory:





 Change into the display mode
 Press the  button several times → display Rcxx
 Press the  button 1x → display x.xx / x.xx (tripping value or error no. / time that has passed in hours)
 Press the  button 1x, go to next alarm

The alarm memory is only deleted during a program change.

8.11 Standby counter and standby time





The standby counter **StBY**, is increased by 1 with every standby shut-down. Up to 9999 shut-downs are counted. That lets the UFR1001E quickly detect how often, e.g., shut-down was performed through a ripple control receiver.

Query the standby counter:





 Change into the display mode
 Press the  button several times until → display Rcxx
 Press the  button 2x → display StBY / xxxx

The standby time **StBY** indicates how long the relay was switched off by the standby mode. It is recorded with a resolution of 1 minute and only when the control voltage is applied and if no alarm is present.

Query the standby time:

 Change into the display mode
 Press the  button several times until → display Rcxx
 Press the  button 3x → display StBY / x.xx (Time LED is illuminated)

Delete the standby counter and standby time (only together):











 Display alarm counter Rcxx
 Press the  button 2x → display StBY / xxxx
 Keep the  button pressed for 2s until → display StBY / 0

8.12 Code lock

You can protect the set parameters by enabling the code lock here.

The device acknowledges an incorrect entry with **Err** (flashes three times).

Adjustment process:

 Select the menu item with the ▲▼ buttons until → display CoDE .
 Press the ▶ button 1x → display Pin / 0
 Set the saved pin code with the ▲▼ buttons (default setting is 504)
 Press the ▶ button 1x → display CoDE / oFF
 Use the ▲▼ buttons to set the desired code lock: <ul style="list-style-type: none">○ oFF off, all parameters can be changed○ oN on, no parameters can be changed
 Press the ▶ button 1x → display Pin / 504
 Use the ▲▼ buttons to set the new, desired pin code (caution: write down the pin code)
 Press the ▶ button 1x
 Code lock on, display oN flashes three times
 Code lock off, display oFF flashes three times
 Return to menu mode, menu item code lock

If there are any problems with the code lock (pin forgotten), the lock can be switched off and the pin can be reset to 504 by keeping the Set key pressed while switching on the mains until ▶ **CoDE** / **oFF** appears in the display.





8.13 Sealing

All the settings and the simulation mode can be locked.

If the  LED is illuminated, the UFR1001E is locked.

If an attempt is made to change a setting in the locked state, for 3s the display shows **Loc** .

Adjustment procedure Sealing/Lock ON (OFF):

 If present, remove seal (only authorised person)
 Apply control supply voltage at A1-A2
 Slightly lift the key cover and turn 180°
 Actuate the small blue button by <u>pressing the button cover very firmly</u> (LED starts flashing) until the green LED  is illuminated.





8.14 Simulation

Here, the voltage, frequency or a vector surge can be simulated and the setting can be tested. All 3 phases plus the 10 minute mean value are always simulated. All functions of the device operate as if this value is actually being measured. Alarm and error messages are only indicated with the LEDs and not in the display.

The set values are simulated until the menu item **S_i** is exited with the ▲ or ▼ button. If the UFR1001E is sealed/locked, simulation is not possible.

If the section switch feedback contacts are connected to the UFR1001E and enabled, (set value > section-switch turn-on time under **t_rEL**), after a shut-down, the tripping time (dAL + time of slowest section switch) is displayed.

Adjustment process:

 Select the menu item with the ▲▼ buttons until → display S_i
 Press the ▶ button 1x → display S_i / U
 Use the ▲▼ buttons to set the measurement factor for simulation: <ul style="list-style-type: none">○ U Voltage + 10min mean value (frequency = last simulated value)○ F Frequency (voltage = last simulated value)○ u_{Sr} Vector shift
 Press the ▶ button 1x → display 230 (selected measurement factor is simulated)
 Use the ▲▼ buttons to set the desired value

After exiting the Simulation menu item with the ▲▼ buttons, the unit switches over to monitoring the limits.

The unit automatically returns to the display mode if no button is pressed for 15 minutes.

Hint: A limit value should be tested that is higher than the set 10min mean value. If the 10min mean value has to be temporarily switched off, set (**U_n** → **oFF**) since otherwise it will trip first. The same applies, for example, for **U⁻**, during a simulation of **U⁻** in Pr3 and Pr4. (Medium voltage)

8.15 Possible indications in display

Display mode

AL , AN	Alarm , Alarm 10min mean value
Err4 ... Err9	Error messages (see 11. Error messages and measures)
Rc , tAL	Alarm counter, cumulative alarm time
Scn , n	Scan mode, 10min mean value

Menu mode / configuration mode

U ⁻ , U ⁻ , U ₋ , U ₋	Voltage limit value
UN	Limit value 10min mean value
H ⁻ , H ⁻ , H ₋ , H ₋ , HN	Hysteresis (if a limit value is changed, the reset value also shifts; that means it might be necessary to adapt it)
F ⁻ , F ⁻ , F ₋ , F ₋ , dFdt	Frequency limit value, ROCOF (df/dt) limit value
dAL	Response time
doF	Reset time; is always counted down in the display
uSr	Vector surge
Stby	Standby mode, standby-time, standby-counter
y1y2	Evaluation of the feedback contacts is suppressed when E1-E2 are closed
dEon	Delay Enable On, suppression time when switching on and after opening the enable input
1 Ph , 3 Ph	Single phase, three-phase vector shift evaluation
rocoF , PEr	ROCOF (df/dt), Periods
rEL	Relay
t _r EL	Section switch turn-on time, <input type="checkbox"/> OFF no feedback contacts
dd _i	Delay display, to calm down the display
d _i t	Display duration scan mode (each measurement is displayed for this duration)
S _i , F , U	Simulation, Frequency, voltage
CoDE , PLo , uSr	Code lock / sealing, vector shift
P _i n	Pin code (default 504)
Info	Device information, program change
F _{nr} , S _{nr}	Firmware version, serial number
h	Operating hours
Err , dEL	Error counter, delete error counter
YES , no	Yes, no query for acknowledgement
Pr	Program
on , off	On, Off

9. Default settings and firmware version, VDE-AR-N 4105 + BDEW

When changing programs, all parameters are reset to the default settings.

Menu	Parameter / Unit		Default settings 							Users Data
			Low voltage VDE-AR-N 4105			Medium voltage BDEW				
			3 AC+N 230V	3 AC 400V	2/1 AC+N 230V	3 AC+N 57,7V	3 AC 100V	3/2/1AC +N 230V	3 AC 400V	
			Pr1*	Pr2	Pr7	Pr3	Pr4	Pr5	Pr6	
U [~]	U [~] Alarm on/off		-	-	-	on	on	on	on	
	U [~] Overvoltage	V	-	-	-	66.4	115	264	458	
	H [~] Hysteresis	V	-	-	-	1.0	1.0	3.0	3.0	
	dRL Response time	s	-	-	-	0.10	0.10	0.10	0.10	
	doF OFF-delay	s	-	-	-	60	60	60	60	
U ⁻	U ⁻ Alarm on/off		on	on	on	on	on	on	on	
	U ⁻ Overvoltage	V	264	458	264	62.3	108	249	430	
	H ⁻ Hysteresis	V	5.0	5.0	5.0	1.0	1.0	3.0	3.0	
	dRL Response time	s	0.10	0.10	0.10	60.00	60.00	60.00	60.00	
	doF OFF-delay	s	60	60	60	60	60	60	60	
UN	UN Alarm on/off		on	on	on	oFF	oFF	oFF	oFF	
	UN Overvoltage	V	253	438	253	63.5	110	253	438	
	HN Hysteresis	V	3.0	3.0	3.0	1.0	1.0	3.0	3.0	
	dRL Response time	s	0.10	0.10	0.10	0.10	0.10	0.10	0.10	
	doF OFF-delay	s	60	60	60	60	60	60	60	
U ₋	U ₋ Alarm on/off		on	on	on	on	on	on	on	
	U ₋ Undervoltage	V	184	318	184	46.2	80.0	184	318	
	H ₋ Hysteresis	V	5.0	5.0	5.0	1.0	1.0	3.0	3.0	
	dRL Response time	s	0.10	0.10	0.10	2.70	2.70	2.70	2.70	
	doF OFF-delay	s	60	60	60	60	60	60	60	
U _~	U _~ Alarm on/off		-	-	-	oFF	oFF	oFF	oFF	
	U _~ Undervoltage	V	-	-	-	26.0	45.0	104	180	
	H _~ Hysteresis	V	-	-	-	1.0	1.0	2.0	2.0	
	dRL Response time	s	-	-	-	0.30	0.30	0.30	0.30	
	doF OFF-delay	s	-	-	-	60	60	60	60	
F [~]	F [~] Alarm on/off		-	-	-	oFF	oFF	oFF	oFF	
	F [~] Overfrequency	Hz	-	-	-	51.50	51.50	51.50	51.50	
	H [~] Hysteresis	Hz	-	-	-	1.45	1.45	1.45	1.45	
	dRL Response time	s	-	-	-	0.10	0.10	0.10	0.10	
	doF OFF-delay	s	-	-	-	60	60	60	60	
F ⁻	F ⁻ Alarm on/off		on	on	on	on	on	on	on	
	F ⁻ Overfrequency	Hz	51.50	51.50	51.50	51.50	51.50	51.50	51.50	
	H ⁻ Hysteresis	Hz	1.45	1.45	1.45	1.45	1.45	1.45	1.45	
	dRL Response time	s	0.10	0.10	0.10	0.10	0.10	0.10	0.10	
	doF OFF-delay	s	60	60	60	60	60	60	60	

Menu	Parameter / Unit		Default settings 							Users Data	
			Low voltage VDE-AR-N 4105			Medium voltage BDEW					
			3 AC+N 230V	3 AC 400V	2/1AC+N 230V	3AC+N 57,7V	3 AC 100V	3/2/1AC +N 230V	3 AC 400V		
			Pr 1 *	Pr 2	Pr 3	Pr 4	Pr 5	Pr 6			
F ₋	F ₋	Alarm on/off		on	on	on	on	on	on	on	
	F ₋	Underfrequency	Hz	47.50	47.50	47.50	47.50	47.50	47.50	47.50	
	H ₋	Hysteresis	Hz	1.00	1.00	1.00	1.00	1.00	1.00	1.00	
	d _{FL}	Response time	s	0.10	0.10	0.10	0.10	0.10	0.10	0.10	
	d _{oF}	OFF-delay	s	60	60	60	60	60	60	60	
F ₋₋	F ₋₋	Alarm on/off		-	-	-	oFF	oFF	oFF	oFF	
	F ₋₋	Underfrequency	Hz	-	-	-	47.50	47.50	47.50	47.50	
	H ₋₋	Hysteresis	Hz	-	-	-	1.00	1.00	1.00	1.00	
	d _{FL}	Response time	s	-	-	-	0.10	0.10	0.10	0.10	
	d _{oF}	OFF-delay	s	-	-	-	60	60	60	60	
u _{5r}	u _{5r}	Alarm on/off		5t6y	5t6y	5t6y	5t6y	5t6y	5t6y	5t6y	
	u _{5r}	Vector shift	°	10.0	10.0	10.0	10.0	10.0	10.0	10.0	
	d _{oF}	OFF-delay	s	3	3	3	3	3	3	3	
	d _{Eon}	Suppression time	s	2	2	2	3	3	3	3	
	u _{5r}	Number of phases		3Ph	3Ph	3Ph	3Ph	3Ph	3Ph	3Ph	
r _{ocF}	r _{ocF}	Alarm on/off		oFF	oFF	oFF	oFF	oFF	oFF	oFF	
	d _{Fdt}	delta f / delta t	Hz /s	0.800	0.800	0.800	0.800	0.800	0.800	0.800	
	PE _r	periods		4	4	4	4	4	4	4	
	d _{FL}	Response time	s	0.10	0.10	0.10	0.10	0.10	0.10	0.10	
	d _{oF}	OFF-delay	s	60	60	60	60	60	60	60	
r _{EL}	t _{rEL}	Response time	s	5.0	5.0	5.0	oFF	oFF	oFF	oFF	
dd _i	dd _i	Display delay	s	0.5	0.5	0.5	0.5	0.5	0.5	0.5	
	d _{i t}	Display duration 5C _n	s	3.5	3.5	3.5	3.5	3.5	3.5	3.5	
S _i	U	Voltage	V	230	400	230	100	100	230	400	
	F	Frequency	Hz	50.00	50.00	50.00	50.00	50.00	50.00	50.00	
	u _{5r}	Vector shift	°	0.0	0.0	0.0	0.0	0.0	0.0	0.0	
C _{odE}	P _{i n}	Pincode		504	504	504	504	504	504	504	
I _{nFo}	F _{n r}	Firmware version		0-05	0-05	0-05	0-05	0-05	0-05	0-05	
	S _{n r}	Serial number		xxxx	xxxx	xxxx	xxxx	xxxx	xxxx	xxxx	
	h	Operating hours	h	xxxx	xxxx	xxxx	xxxx	xxxx	xxxx	xxxx	
	E _{r r}	Error counter		xxx	xxx	xxx	xxx	xxx	xxx	xxx	
	Pr	Program		1	2	3	4	5	6	6	

* default setting

Display of the program:

I_{nFo}

→

Pr

or when switching on

Display of the firmware version:



I_{nFo}

→



F_{n r}

9.1 Default settings and firmware version, ÖVE/ÖNORM E 8001-4-712, G83/2+G59/3

When changing programs, all parameters are reset to the default settings.

Menu	Parameter / Unit		Default settings					Users Data
			 ÖVE/ÖNORM E 8001-4-712		 G83/2 + G59/3			
			3AC+N 230V	3AC+N 230V *	3AC 400V *	3AC+N 57,7V *	3AC 100V *	
			Pr 10	Pr 20	Pr 21	Pr 22	Pr 23	
U ⁺⁺	U ⁺⁺ Alarm on/off		-	on	on	on	on	
	U ⁺⁺ Overvoltage	V	-	273	476	68.7	119	
	H ⁺⁺ Hysteresis	V	-	5.0	5.0	1.0	1.0	
	dRL Response time	s	-	0.50	0.50	0.50	0.50	
	doF OFF-delay	s	-	20	20	20	20	
U ⁻	U ⁻ Alarm on/off		on	on	on	on	on	
	U ⁻ Overvoltage	V	264	262	456	65.8	114	
	H ⁻ Hysteresis	V	5.0	5.0	5.0	1.0	1.0	
	dRL Response time	s	0.10	1.00	1.00	1.00	1.00	
	doF OFF-delay	s	30	20	20	20	20	
U [∏]	U [∏] Alarm on/off		on	oFF	oFF	oFF	oFF	
	U [∏] Overvoltage	V	258	262	456	65.8	114	
	H [∏] Hysteresis	V	3.0	5.0	5.0	1.0	1.0	
	dRL Response time	s	0.10	1.00	1.00	1.00	1.00	
	doF OFF-delay	s	30	20	20	20	20	
U ₋	U ₋ Alarm on/off		on	on	on	on	on	
	U ₋ Undervoltage	V	184	200	348	50.2	87.0	
	H ₋ Hysteresis	V	5.0	5.0	5.0	1.0	1.0	
	dRL Response time	s	0.10	2.50	2.50	2.50	2.50	
	doF OFF-delay	s	30	20	20	20	20	
U ₋₋	U ₋₋ Alarm on/off		-	on	on	oFF	oFF	
	U ₋₋ Undervoltage	V	-	184	320	46.2	80.0	
	H ₋₋ Hysteresis	V	-	5.0	5.0	1.0	1.0	
	dRL Response time	s	-	0.50	0.50	0.50	0.50	
	doF OFF-delay	s	-	20	20	20	20	
F ⁺⁺	F ⁺⁺ Alarm on/off		-	on	on	on	on	
	F ⁺⁺ Overfrequency	Hz	-	52.00	52.00	52.00	52.00	
	H ⁺⁺ Hysteresis	Hz	-	1.45	1.45	1.45	1.45	
	dRL Response time	s	-	0.50	0.50	0.50	0.50	
	doF OFF-delay	s	-	20	20	20	20	
F ⁻	F ⁻ Alarm on/off		on	on	on	on	on	
	F ⁻ Overfrequency	Hz	5.150	5.150	5.150	5.150	5.150	
	H ⁻ Hysteresis	Hz	1.45	1.45	1.45	1.45	1.45	
	dRL Response time	s	0.10	90.0	90.0	90.0	90.0	
	doF OFF-delay	s	30	20	20	20	20	

* Pr 20 ... Pr 23 for 240/416 V rated voltage change settings of: Voltage x (240V / 230 V)

Menu	Parameter / Unit		Default setting					Users Data	
									
			ÖVE/ÖNORM E	G83/2 + G59/3					
			3AC+N 230V	3AC+N 230V	3AC 400V	3AC+N 57,7V	3AC 100V		
		Pr 10	Pr 20	Pr 21	Pr 22	Pr 23			
F_	F_	Alarm on/off		on	on	on	on	on	
	F_	Underfrequency	Hz	47.50	47.50	47.50	47.50	47.50	
	H_	Hysteresis	Hz	1.00	1.00	1.00	1.00	1.00	
	dRL	Response time	s	0.10	20.0	20.0	20.0	20.0	
	doF	OFF-delay	s	30	20	20	20	20	
F_	F_	Alarm on/off		-	on	on	on	on	
	F_	Underfrequency	Hz	-	47.00	47.00	47.00	47.00	
	H_	Hysteresis	Hz	-	1.00	1.00	1.00	1.00	
	dRL	Response time	s	-	0.50	0.50	0.50	0.50	
	doF	OFF-delay	s	-	20	20	20	20	
u5r	u5r	Alarm on/off		Stby	Stby	Stby	Stby	Stby	
	u5r	Vector shift	°	10.0	12.0	12.0	12.0	12.0	
	doF	OFF-delay	s	2	20	20	20	20	
	dEon	Suppression time	s	2	2	2	2	2	
	u5r	Number of phases		3Ph	1Ph	1Ph	1Ph	1Ph	
rocF	rocF	Alarm on/off		oFF	on	on	on	on	
	dFdt	delta f / delta t	Hz /s	0.800	0.200	0.200	0.200	0.200	
	PEr	periods		4	40	40	40	40	
	dRL	Response time	s	0.10	0.10	0.10	0.10	0.10	
	doF	OFF-delay	s	30	20	20	20	20	
rEL	ErEL	Response time	s	oFF	oFF	oFF	oFF	oFF	
ddi	ddi	Display delay	s	0.5	0.5	0.5	0.5	0.5	
	di t	Display duration 5Cn	s	3.5	3.5	3.5	3.5	3.5	
Si	U	Voltage	V	230	230	400	57.7	100	
	F	Frequency	Hz	50.00	50.00	50.00	50.00	50.00	
	u5r	Vector shift	°	0.0	0.0	0.0	0.0	0.0	
CodE	Pi n	Pincode		504	504	504	504	504	
Info	Fnr	Firmware version		0-05	0-05	0-05	0-05	0-05	
	Snr	Serial number		xxxx	xxxx	xxxx	xxxx	xxxx	
	h	Operating hours	h	Xxxx	xxxx	xxxx	xxxx	xxxx	
	Err	Error counter		xxx	xxx	xxx	xxx	xxx	
	Pr	Program		10	20	21	22	23	

Display of the program:

Info → Pr

or when switching on

Display of the firmware version:

Info → Fnr

10. Technical Data

Control voltage Us:

Rated connection AC/DC 24-270 V, 0/40...70 Hz, < 5 VA
DC: 20.4...297 V, AC: 20.4...297 V

Output relay:

Switching voltage 2 x change-over contact
Max. AC 440 V
Conventional thermal current I_{th} 6 A
Inrush current (at 10 % ED) 25 A max. 4 s / 50 A max. 1 s
Nominal operating current I_e (AC 15) 6 A AC 250 V
Recommended series fuse gG/gL 6 A
Contact service life, mech. 30 x 10⁶ switching cycles
Contact service life, electr. 1 x 10⁶ operating cycles at AC 250 V / 6 A
2 x 10⁵ operating cycles at AC 250 V / 10 A cos φ 0.6

Voltage measurement:

Measurement voltage phase – phase AC 15...530 V (< 5 V: 0 is displayed)
Adjustment range phase – phase AC 15...520 V
Measurement voltage phase – N AC 10...310 V (< 5 V: 0 is displayed)
Adjustment range phase – N AC 15...300 V
Measurement principle Real root mean square measurement both half waves
Hysteresis Adjustable 1.0...99.9 V
Measurement error (with N) ± 0.6 % of the measurement value
Measurement error (without N) ± 0.8 % of the measurement value
Display accuracy >100V: -1 digit (res. 1 V), <100V: -1 digit (res. 0.1V)
Measurement function 3-phase with/without N
Response time Adjustable 0.05 (±15ms)...130.0 s
Reset time Adjustable 0(>200ms) ... 999 s
Input resistance Phase-N 454 kΩ

Frequency measurement

Frequency range 40...70 Hz
Adjustment range 45.00...65.00 Hz
Hysteresis 0.05...10.00 Hz
Measurement accuracy ± 0.04Hz ± 1 digit
Response time Adjustable 0.05 (±15ms)...130.0 s
Reset time Adjustable 0 (>200ms) ... 999 s

Vector surge

Measurement range 0...45.0°
Adjustment range 2.0...20.0°
Response time < 50 ms
Reset time Adjustable 3...240 s
Delay at Us on Adjustable 2...20 s

ROCOF (df/dt)

Frequency range 40...70 Hz
Adjustment range 0,100...5,000 Hz/s, 4...50 Periods
Hysteresis fixed 0,05Hz
Measurement error ± 0,04Hz ± 1Digit
Response time adjustable 0,05 (±15ms) ... 130,0 s
Reset time adjustable 0 (>200ms) ... 999 s
Measurement time Number of adjusted Periods * Periods duration + Response time

Digital outputs (galvanic isolated)

Switching voltage I1	DC 4.5...27 V
Current Q1...Q5	Max 20 mA / output

Contactor feedback inputs

Voltage / Current Y0 – Y1/2	DC 15...35 V / ca. 4mA
Voltage / Current E1 – E2	DC 15...35 V / ca. 6mA
Contactor response time (section switch)	Adjustable 0.5...99.0 s

Test conditions

	IEC/EN 60255	
Rated impulse voltage	4000 V	
Overvoltage category	III	
Pollution degree	2	
Rated insulation voltage Ui	300 V	
Operating time	100 %	
Operating temperature	-20 °C... +55 °C	
Storage temperature	-25 °C ... +70 °C	
Climatic conditions (IEC/EN 60721-3-3)	3K5 (except condensation and formation of ice)	
Tests IEC/EN 60255-1		
Storage tests		
Dry heat	IEC 60068-2-2	+ 70 °C 16 h
Cold	IEC 60068-2-1	- 25 °C 16 h
Operational tests		
Dry heat	IEC 60068-2-2	+ 55 °C 16 h
Cold	IEC 60068-2-1	- 20 °C 16 h
Cyclic temperature	IEC 60068-2-14	- 25 °C / + 55 °C 5 cycle 3 + 3 h
Damp heat steady state	IEC 60068-2-78	+ 40 °C 95 % RH 21 days
Cyclic temperature with humidity	IEC 60068-2-30	+ 25 °C 97% RH / + 55 °C 93 % RH 6 cycle 12 + 12 h
IEC 60255-21-1	vibration	class 1
IEC 60255-21-2	shock	class 1
IEC 60255-21-3	seismic test	class 1

EMC - immunity	EN 61000-6-2
EMC - emission	EN 61000-6-3

Housing:

Construction form	V6
Front-to-back size	55 mm
Dimensions (W x H x D)	90 x 105 x 69 mm
Wiring connection single strand	each 1 x 4mm ²
Finely stranded with wire end ferrule	each 1 x 2.5mm ²
Protection class, housing	IP 30
Protection class, terminals	IP 20
Mounting	snap-on fastening on 35 mm mounting rail acc EN 60 715 or with M4 screwed attachment (additional bar not included in the scope of delivery)
Weight:	approx. 250 g

We reserve the right to make technical changes

11. Maintenance and repair

The UFR1001E is maintenance-free. Periodically test for proper functioning.

12. Troubleshooting and measures

Error	Cause	Remedy
EEEE or -EEE appears in the display	Measurement is above/below range	Measured voltage, frequency or the vector surge is too large or too small; comply with measurement range
Err4 appears in the display	Tolerance error, internal measurement value deviation of both channels	Perform a reset → interrupt control voltage for >5s *
Err5 appears in the display	Error internal interface	
Err6 appears in the display	Communication error, internal interface	
Err7 also appears in the display after 2 automatic reconnection attempts, LED K1 and / or K2 illuminated	Feedback contacts connected	<u>Feedback contacts not connected</u> Set - rEL . → tREL . → oFF <u>Feedback contacts not connected</u> - Check for correct connection - Set turn-on time of section switch under tREL . - Perform a reset → interrupt control voltage for >5s
Err8 appears in the display	Hysteresis error	Upper threshold value must be higher than the lower threshold value, check the threshold values
Err9 appears in the display	Parameter error	Reset to factory settings, see “Program setup” *
A time expires in the display	Always when an OFF-delay time doF is running, it is counted down in the display (shortest one first)	Wait until the time has expired (depending on the setting, several times may elapse one after the other)
Device cannot be configured / only the limits can be configured	Code lock / Sealing activated	If there are any problems with the code lock (pin forgotten), the lock can be switched off and the pin can be reset to 504 by keeping the Set key pressed while switching on the mains until CoDE / oFF appears in the display.
Implausible voltage values	Pr selected with N, but N not connected	Select Pr without N or connect N
Loc appears in the display	Seal is active	See Sealing
CoDE appears in the display	Code lock is active	See „Code lock“
Stby appears in the display	Standby mode, E1-E2 closed	Check parameter u5r .
RL and LED Q3 (f>) is on, reading in good range	hysteresis for F⁻ incorrectly	Check hysteresis for reset point 50,05 Hz

* If the error cannot be patched by a reset, send back to factory for repair.

13. Construction form V6

Dimensions in mm

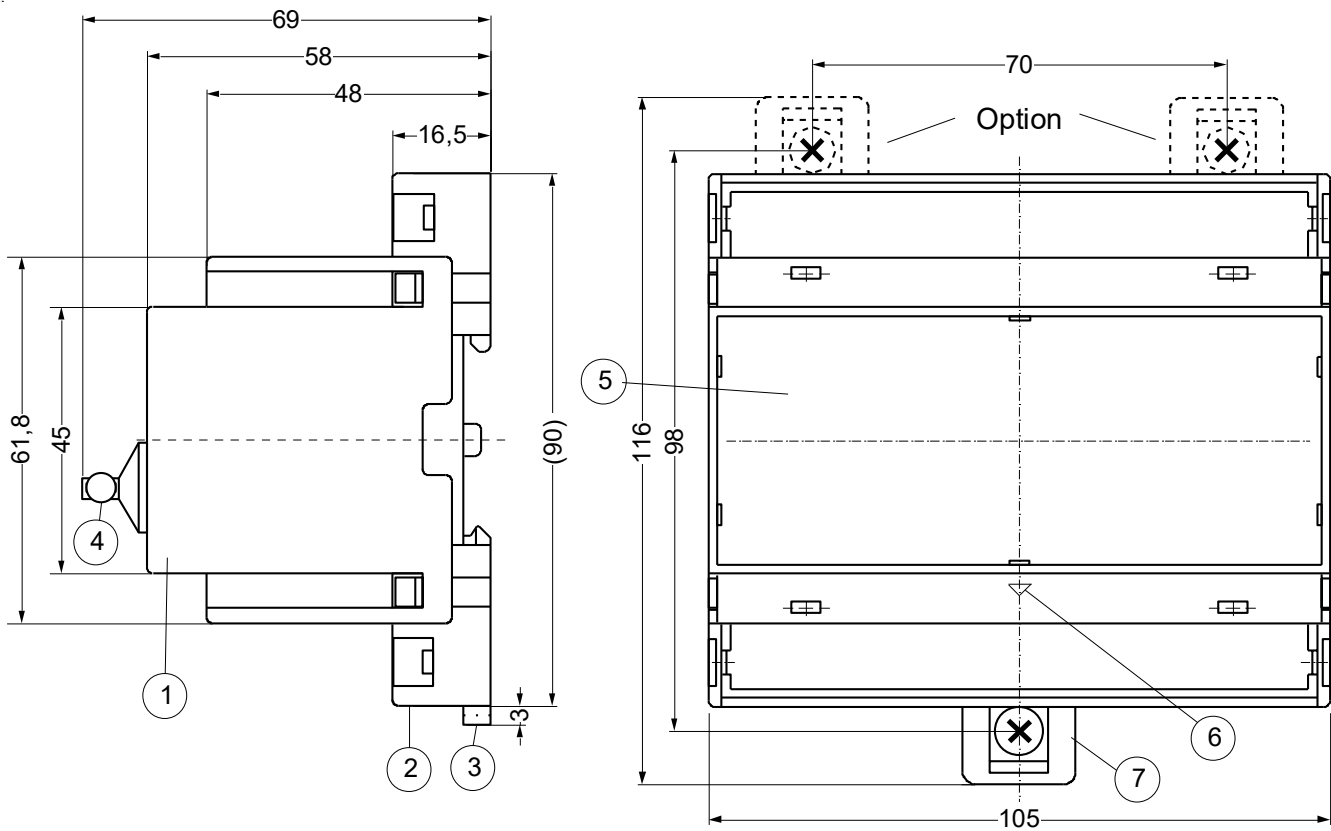

- 1 Oberteil / cover
- 2 Unterteil / base
- 3 Riegel / bar for snap mounting
- 4 Sealing max. \varnothing 1.8 mm
- 5 Frontplatteneinsatz / front panel
- 6 Kennzeichen für unten / position downward
- 7 Bar for wall attachment with screws. Riegelbohrung \varnothing 4,2 mm / Bolt hole for fixing to wall with screws, \varnothing 4.2 mm.



Konformitätsnachweis NA-Schutz

Hersteller / Antragsteller: ZIEHL industrie-elektronik GmbH + CO KG
Daimlerstr.13
74523 Schwäbisch Hall
Deutschland

Typ NA-Schutz:	Zentraler NA-Schutz UFR1001E
----------------	------------------------------

Firmwareversion: 0-0x
Netzanschlussregel: VDE-AR-N 4105:2011-08 – Erzeugungsanlagen am Niederspannungsnetz
Technische Mindestanforderungen für Anschluss und Parallelbetrieb von Erzeugungsanlagen am Niederspannungsnetz
Mitteltende Normen / Richtlinien: DIN VDE V 0124-100 (VDE V 0124-100): 2012-07 – Netzintegration von Erzeugungsanlagen – Niederspannung
Prüfanforderungen an Erzeugungseinheiten vorgesehen zum Anschluss und Parallelbetrieb am Niederspannungsnetz

Der oben bezeichnete NA-Schutz wurde nach der Prüfrichtlinie VDE 0124-100 geprüft und zertifiziert. Die in der Netzanschlussregel geforderten elektrischen Eigenschaften werden erfüllt:

- Einstellwerte und die Abschaltzeiten
- Technische Anforderungen der Schalteinrichtung
- Passive Inselnetzserkennung
- Einfehlersicherheit

Das Zertifikat beinhaltet folgende Angaben:

- Technische Daten des NA-Schutz
- Einstellwerte der Schutzfunktionen
- Auslösewerte der Schutzfunktionen

BV Projektnummer: 11TH0501
Zertifikatsnummer: U14-0647
Ausstellungsdatum: 2014-12-03

Zertifizierungsstelle

Dieter Zitzmann

(Eine auszugsweise Darstellung des Zertifikats bedarf der schriftlichen Genehmigung der BV CPS GmbH)



Zertifizierungsstelle der Bureau Veritas Consumer Products Services Germany GmbH
Akkreditiert nach EN 45011 - ISO / IEC Guide 65

F.4 Anforderungen an den Prüfbericht zum NA-Schutz

Auszug aus dem Prüfbericht für den NA-Schutz
„Bestimmung der elektrischen Eigenschaften“

Nr. 11TH0501

NA-Schutz als integrierter NA-Schutz

Hersteller / Antragsteller:	ZIEHL industrie-elektronik GmbH + CO KG Daimlerstr.13 74523 Schwäbisch Hall Deutschland
------------------------------------	--

Typ NA-Schutz:	Zentraler NA-Schutz UFR1001E
-----------------------	------------------------------

Firmwareversion:	0-0x*
-------------------------	-------

* Die Prüfungen wurden mit Firmwareversion 0-00 durchgeführt. Die Änderungen der Firmwareversion auf 0-0x hat keinen Einfluss auf die in der Netzanschlussregel geforderten elektrischen Eigenschaften.

x = beliebige Zahl oder Zeichen

Messzeitraum:	2012-01-26 – 2012-02-02
----------------------	-------------------------

Schutzfunktion	Einstellwert	Auslösewert	Auslösezeit NA-Schutz ^a
Spannungsrückgangsschutz U<	184 V	183,9 V	98 ms
Spannungssteigerungsschutz U>	253 V	---	536 s ^b
Spannungssteigerungsschutz U>>	264 V	263,8 V	98 ms
Frequenzrückgangsschutz f<	47,50 Hz	47,51 Hz	80 ms
Frequenzsteigerungsschutz f>	51,50 Hz	51,51 Hz	93 ms

^a Die Auslösezeit umfasst den Zeitraum von der Grenzwertverletzung U/f bis zum Auslösesignal an dem Kuppelschalter.

^b längste Abschaltung des Spannungssteigerungsschutz als gleitender 10-min-Mittelwert, geprüft gemäß Punkt 5.4.5.3.3 Messung a) der VDE 0124-100

Bei der Planung der Erzeugungsanlage ist die Eigenzeit des Kuppelschalters zum höchsten oben ermittelten Zeitwert zu addieren.

Die Abschaltzeit (Summe der Auslösezeit NA-Schutz zzgl. Eigenzeit des Kuppelschalters) darf 200 ms nicht überschreiten.

Der oben genannte NA-Schutz erfüllt die Anforderungen zur Synchronisation.



**BUREAU
VERITAS**

Konformitätsnachweis

Antragsteller: ZIEHL industrie-elektronik GmbH + CO KG
Daimlerstr.13
74523 Schwäbisch Hall
Deutschland

Typ NA-Schutz:	Zentraler NA-Schutz	UFR1001E
-----------------------	----------------------------	-----------------

Firmwareversion 0-0x (Erläuterung siehe Anhang)

Netzanschlussregel: BDEW-Richtlinie „Erzeugungsanlagen am Mittelspannungsnetz“
Richtlinie für Anschluss und Parallelbetrieb von Erzeugungsanlagen am Mittelspannungsnetz, 2008 und Ergänzung bis einschließlich 1/2013

Mitgeltende Normen / Richtlinien: DIN EN 61400-21:2008;
Technische Richtlinien: TR3 Rev. 23, TR8 Rev. 6

Der oben bezeichnete NA-Schutz wurde nach folgenden Kapiteln, der in der Netzanschlussregel referenzierten technischen Richtlinien, geprüft:

- Einstellwerte und Abschaltzeiten (Kapitel 4.5 in TR3 und 5.1.7 in TR8)
- Rückfallverhältnis (Kapitel 4.5 in TR3 und 5.1.7 in TR8)
- Wiedereinschaltbedingungen (Kapitel 4.6 in TR3 und 5.1.3.1 in TR8)

Das Zertifikat beinhaltet folgenden Anhang:

- Auslösewerte der Schutzfunktionen
- Einstellwerte der Schutzfunktionen

BV Berichtsnummer: 11TH0501_TR3

Zertifikatsnummer: 12-095_1

Ausstellungsdatum: 2014-07-23

Zertifizierungsstelle

Dieter Zitzmann



Deutsche
Akkreditierungsstelle
D-ZE-12024-01-01

Zertifizierungsstelle der Bureau Veritas Consumer Products Services Germany GmbH
Akkreditiert nach EN 45011 - ISO / IEC Guide 65

Eine auszugsweise Darstellung des Zertifikats bedarf der schriftlichen Genehmigung der BV CPS GmbH.

(S. 1 von 7)

Auszug aus dem Prüfbericht (11TH0501_TR3)				
Firmware des NA-Schutzes				
Geprüfte Version	0-01 und 0-05			
Zugelassene Version	0-0x mit x = 1 und höher			
TR 3 – 4.5 Trennung der EZE vom Netz				
	Einstellwert	Auslösewert	Einstellwert [ms]	Abschaltzeit [ms]
Frequenzrückgangsschutz	47,50 Hz	47,51 Hz	100	101,3 ... 104,3
Frequenzrückgangsschutz (schnellstmöglich)	47,50 Hz	47,51 Hz	50	51,1 ... 53,1
Frequenzsteigerungsschutz	51,50 Hz	51,50 Hz	100	101,4 ... 101,9
Spannungsrückgangsschutz (1. Stufe)	184,0 V	184,1 V	2.400	2.379,9 ... 2.399,0
Spannungsrückgangsschutz (schnellstmöglich)	184,0 V	184,1 V	50	49,1 ... 49,5
Spannungsrückgangsschutz (2. Stufe)	104,0 V	105,1 V	300	297,6 ... 309,0
Spannungssteigerungsschutz (2. Stufe)	276,0 V	275,7 V	100	97,9 ... 101,1
zusätzliche Prüfung mit Firmware 0-05				
Spannungsrückgangsschutz (1. Stufe)	23,0 V	23,2 V	2.400	2.405 ... 2.411
Spannungsrückgangsschutz (2. Stufe)	23,0 V	23,2 V	300	303,3 ... 310,8
Spannungssteigerungsschutz (1. Stufe)	299,0 V	299,6 V	60.000	60.000
Spannungssteigerungsschutz (2. Stufe)	299,0 V	299,5 V	100	103,8 ... 110,3
Anmerkung:				
Entsprechend der Erfassung im Schutzgerät sind die Spannungen als Phase-Neutral-Werte ausgewiesen. In der für diese Netzanschlussregel vorgesehenen Funktionalität werden im Schutzgerät die Phase-Phase-Werte nicht überwacht.				
Die angegebenen Abschaltzeiten beinhalten nur die Einstellzeit und Eigenzeit des Schutzgerätes.				
Das Rückfallverhältnis wird eingehalten.				
Die maximalen bzw. minimalen messbaren Abschaltsschwellen und Verzögerungszeiten gemäß TR 8 – 5.1.7.2 wurden vermessen.				
Die notwendige Messgenauigkeit der Schutzeinrichtung ist durch die erfolgreiche Vermessung nachgewiesen.				

Auszug aus dem Prüfbericht (11TH0501_TR3)

Einstellbare Parameter (<i>Herstellerangabe</i>) (getestet)	
1. Unterfrequenzschwelle-Parametername	F ₋
1. Unterfrequenzschwelle-Parameterdimension	Hz
1. Unterfrequenzschwelle-Parameterbereich	45,00 – 65,00
1. Unterfrequenzschwelle-Parameterschrittweite	0,01
1. Unterfrequenzhysterese-Parametername	H ₋
1. Unterfrequenzhysterese-Parameterdimension	Hz
1. Unterfrequenzhysterese-Parameterbereich	0,05 – 10,00
1. Unterfrequenzhysterese-Parameterschrittweite	0,05
1. Unterfrequenzverzögerungszeit-Parametername	dAL
1. Unterfrequenzverzögerungszeit-Parameterdimension	s
1. Unterfrequenzverzögerungszeit-Parameterbereich	0,05 – 60,00
1. Unterfrequenzverzögerungszeit-Parameterschrittweite	0,01
1. Überfrequenzschwelle-Parametername	F ⁻
1. Überfrequenzschwelle-Parameterdimension	Hz
1. Überfrequenzschwelle-Parameterbereich	45,00 – 65,00
1. Überfrequenzschwelle-Parameterschrittweite	0,01
1. Überfrequenzhysterese-Parametername	H ⁻
1. Überfrequenzhysterese-Parameterdimension	Hz
1. Überfrequenzhysterese-Parameterbereich	0,05 – 10,00
1. Überfrequenzhysterese-Parameterschrittweite	0,05
1. Überfrequenzverzögerungszeit-Parametername	dAL
1. Überfrequenzverzögerungszeit-Parameterdimension	s
1. Überfrequenzverzögerungszeit-Parameterbereich	0,05 – 60,00
1. Überfrequenzverzögerungszeit-Parameterschrittweite	0,01
1. Unterspannungsschwelle-Parametername	U ₋
1. Unterspannungsschwelle-Parameterdimension	V
1. Unterspannungsschwelle-Parameterbereich	15,0 – 300,0
1. Unterspannungsschwelle-Parameterschrittweite	range 15,0 - 99,9: 0,1 / range 100 – 300: 1
1. Unterspannungshysterese-Parametername	H ₋
1. Unterspannungshysterese-Parameterdimension	V
1. Unterspannungshysterese-Parameterbereich	1,0 – 99,9
1. Unterspannungshysterese-Parameterschrittweite	0,1
1. Unterspannungsverzögerungszeit-Parametername	dAL
1. Unterspannungsverzögerungszeit-Parameterdimension	s
1. Unterspannungsverzögerungszeit-Parameterbereich	0,05 – 130,00
1. Unterspannungsverzögerungszeit-Parameterschrittweite	0,01

Auszug aus dem Prüfbericht (11TH0501_TR3)	
2. Unterspannungsschwelle-Parametername	U ₋₋
2. Unterspannungsschwelle-Parameterdimension	V
2. Unterspannungsschwelle-Parameterbereich	15,0 – 300,0
2. Unterspannungsschwelle-Parameterschrittweite	range 15,0 - 99,9: 0,1 / range 100 – 300: 1
2. Unterspannungshysterese-Parametername	H ₋₋
2. Unterspannungshysterese-Parameterdimension	V
2. Unterspannungshysterese-Parameterbereich	1,0 – 99,9
2. Unterspannungshysterese-Parameterschrittweite	0,1
2. Unterspannungsverzögerungszeit-Parametername	dAL
2. Unterspannungsverzögerungszeit-Parameterdimension	s
2. Unterspannungsverzögerungszeit-Parameterbereich	0,05 – 130,00
2. Unterspannungsverzögerungszeit-Parameterschrittweite	0,01
1. Überspannungsschwelle-Parametername	U ⁻
1. Überspannungsschwelle-Parameterdimension	V
1. Überspannungsschwelle-Parameterbereich	15,0 – 300,0
1. Überspannungsschwelle-Parameterschrittweite	range 15,0 - 99,9: 0,1 / range 100 – 300: 1
1. Überspannungshysterese-Parametername	H ⁻
1. Überspannungshysterese-Parameterdimension	V
1. Überspannungshysterese-Parameterbereich	1,0 – 99,9
1. Überspannungshysterese-Parameterschrittweite	0,1
1. Überspannungsverzögerungszeit-Parametername	dAL
1. Überspannungsverzögerungszeit-Parameterdimension	s
1. Überspannungsverzögerungszeit-Parameterbereich	0,05 – 130,0
1. Überspannungsverzögerungszeit-Parameterschrittweite	0,01
2. Überspannungsschwelle-Parametername	U ^{- -}
2. Überspannungsschwelle-Parameterdimension	V
2. Überspannungsschwelle-Parameterbereich	15,0 – 300,0
2. Überspannungsschwelle-Parameterschrittweite	range 15,0 - 99,9: 0,1 / range 100 – 300: 1
2. Überspannungshysterese-Parametername	H ^{- -}
2. Überspannungshysterese-Parameterdimension	V
2. Überspannungshysterese-Parameterbereich	1,0 – 99,9
2. Überspannungshysterese-Parameterschrittweite	0,1
2. Überspannungsverzögerungszeit-Parametername	dAL
2. Überspannungsverzögerungszeit-Parameterdimension	s
2. Überspannungsverzögerungszeit-Parameterbereich	0,05 – 130,0
2. Überspannungsverzögerungszeit-Parameterschrittweite	0,01

Auszug aus dem Prüfbericht (11TH0501_TR3)	
Einstellbare Parameter (Herstellerangabe) (nicht getestet)	
10 min-Überspannungsschwelle-Parametername	U $\bar{\cap}$
10 min-Überspannungsschwelle-Parameterdimension	V
10 min-Überspannungsschwelle-Parameterbereich	15,0 – 300,0
10 min-Überspannungsschwelle-Parameterschrittweite	range 15,0 - 99,9: 0,1 / range 100 – 300: 1
10 min-Überspannungshysterese-Parametername	H $\bar{\cap}$
10 min-Überspannungshysterese-Parameterdimension	V
10 min-Überspannungshysterese-Parameterbereich	1,0 – 99,9
10 min-Überspannungshysterese-Parameterschrittweite	0,1
10 min-Überspannungsverzögerungszeit-Parametername	dAL
10 min-Überspannungsverzögerungszeit-Parameterdimension	s
10 min-Überspannungsverzögerungszeit-Parameterbereich	0,05 – 130,0
10 min-Überspannungsverzögerungszeit-Parameterschrittweite	0,01
2. Unterfrequenzschwelle-Parametername	F $\bar{_}$
2. Unterfrequenzschwelle-Parameterdimension	Hz
2. Unterfrequenzschwelle-Parameterbereich	45,00 – 65,00
2. Unterfrequenzschwelle-Parameterschrittweite	0,01
2. Unterfrequenzhysterese-Parametername	H $\bar{_}$
2. Unterfrequenzhysterese-Parameterdimension	Hz
2. Unterfrequenzhysterese-Parameterbereich	0,05 – 10,00
2. Unterfrequenzhysterese-Parameterschrittweite	0,05
2. Unterfrequenzverzögerungszeit-Parametername	dAL
2. Unterfrequenzverzögerungszeit-Parameterdimension	s
2. Unterfrequenzverzögerungszeit-Parameterbereich	0,05 – 60,00
2. Unterfrequenzverzögerungszeit-Parameterschrittweite	0,01
2. Überfrequenzschwelle-Parametername	F $\bar{\bar{}}$
2. Überfrequenzschwelle-Parameterdimension	Hz
2. Überfrequenzschwelle-Parameterbereich	45,00 – 65,00
2. Überfrequenzschwelle-Parameterschrittweite	0,01
2. Überfrequenzhysterese-Parametername	H $\bar{\bar{}}$
2. Überfrequenzhysterese-Parameterdimension	Hz
2. Überfrequenzhysterese-Parameterbereich	0,05 – 10,00
2. Überfrequenzhysterese-Parameterschrittweite	0,05
2. Überfrequenzverzögerungszeit-Parametername	dAL
2. Überfrequenzverzögerungszeit-Parameterdimension	s
2. Überfrequenzverzögerungszeit-Parameterbereich	0,05 – 60,00
2. Überfrequenzverzögerungszeit-Parameterschrittweite	0,01
Betriebsgrenzen (Herstellerangabe)	
Spannungsfestigkeit / Maximale tolerierbare Spannung	310 V P-N RMS 530 V P-P RMS

Auszug aus dem Prüfbericht (11TH0501_TR3)**Anmerkung (Herstellerangabe):**

Die beschriebenen Parameterbereiche erlauben einen kontinuierlichen Betrieb der Netzüberwachung. Hierbei unterlaufen keinerlei andere Funktionen die gewählten Einstellungen.

Die Netzüberwachung kann bei Spannungseinbrüchen auf $\geq 20,4 \text{ V}$ über 3 s hinaus und bei Einbrüchen auf $< 20,4 \text{ V}$ für 500 ms aufrechterhalten werden. Zur Aufrechterhaltung der Funktionalität bei Spannungseinbrüchen $< 20,4 \text{ V}$ über 500 ms hinaus muss eine zusätzliche externe Versorgung vorgesehen werden.

Fällt die Versorgung der Netzüberwachung aus, so führt dies zu einer unverzögerten Trennung vom Netz.

Die integrierte Netzüberwachung ist einfehlersicher implementiert (nachgewiesen durch eine Bescheinigung entsprechend DIN V VDE V 0126-1-1/A1:2012-02).

Das Schutzgerät überwacht die Phase-Phase- (oder Phase-Neutral-)Spannungen.

Die drei Phase-Phase-Spannungen wirken logisch ODER-verknüpft auf das Auslösesignal.

Die drei Phase-Neutral-Spannungen wirken logisch ODER-verknüpft auf das Auslösesignal.

Beschreibung der Feldprüfung der Netzüberwachung (Herstellerangaben)

Das Schutzgerät bietet keine Prüfklemmleiste. Für einen Feldtest muss ein externes Überwachungsgerät mit entsprechender Prüfklemmleiste vorgeschaltet und die Netzüberwachung des Schutzgerätes entsprechend parametrierbar werden. Die Parameter für Netzüberwachung/-schutz können auf dem Display kontrolliert werden.

Auszug aus dem Prüfbericht (11TH0501_TR3)

TR 3 – 4.6 Zuschaltbedingungen

	Einstellwert	Zuschaltung bei
Unterspannung [V]	184,0 + Hysterese 34,5 → 218,5	218,5
Unterfrequenz [Hz]	47,50 + Hysterese 0,05 → 47,55	47,56
Überfrequenz [Hz]	51,5 + Hysterese 1,45 → 50,05	50,05
Einstellbare Parameter (<i>Herstellerangabe</i>)		
Unterspannungsschwelle-Parametername	U ₋	
Unterspannungsschwelle/-hysterese-Parameterdimension	V	
Unterspannungsschwelle-Parameterbereich	15,0 – 300,0	
Unterspannungsschwelle-Parameterschrittweite	range 15,0 - 99,9: 0,1 / range 100 – 300: 1	
Unterspannungsschwelle-Parameter getestet	184,0	
Unterspannungshysterese-Parametername	H ₋	
Unterspannungshysterese-Parameterbereich	1,0 – 99,9	
Unterspannungshysterese-Parameterschrittweite	0,1	
Unterspannungshysterese-Parameter getestet	34,5	
Unterfrequenzschwelle-Parametername	F ₋	
Unterfrequenzschwelle/-hysterese-Parameterdimension	Hz	
Unterfrequenzschwelle-Parameterbereich	45,00 – 65,00	
Unterfrequenzschwelle-Parameterschrittweite	0,01	
Unterfrequenzschwelle-Parameter getestet	47,50	
Unterfrequenzhysterese-Parametername	H ₋	
Unterfrequenzhysterese-Parameterbereich	0,05 – 10,0	
Unterfrequenzhysterese-Parameterschrittweite	0,05	
Unterfrequenzhysterese-Parameter getestet	0,05	
Überfrequenzschwelle-Parametername	F ⁻	
Überfrequenzschwelle/-hysterese-Parameterdimension	Hz	
Überfrequenzschwelle-Parameterbereich	45,00 – 65,00	
Überfrequenzschwelle-Parameterschrittweite	0,01	
Überfrequenzschwelle-Parameter getestet	51,50	
Überfrequenzhysterese-Parametername	H ⁻	
Überfrequenzhysterese-Parameterbereich	0,05 – 10,0	
Überfrequenzhysterese-Parameterschrittweite	0,05	
Überfrequenzhysterese-Parameter getestet	1,45	
Jeder Schwellenparameter besitzt eine eigene Resynchronisationseinstellmöglichkeit:		
Resynchronisationszeit-Parametername	doF	
Resynchronisationszeit-Parameterdimension	s	
Resynchronisationszeit-Parameterbereich	1 – 999	
Resynchronisationszeit-Parameterschrittweite	1	
Resynchronisationszeit-Parameter voreingestellt	60	



**BUREAU
VERITAS**

**Bureau Veritas
Consumer Products Services
Germany GmbH**
Businesspark A96
86842 Türkheim
Deutschland
+ 49 (0) 4074041-0
cps-tuerkheim@de.bureauveritas.com

Zertifizierungsstelle der BV CPS GmbH
Akkreditiert nach EN 45011 -
ISO / IEC Guide 65

Unbedenklichkeitsbescheinigung

Antragsteller: ZIEHL industrie-elektronik GmbH+Co KG
Daimlerstraße 13
74523 Schwäbisch Hall
Deutschland

Erzeugnis: Selbsttätige Schaltstelle zwischen einer netzparallelen
Eigenerzeugungsanlage und dem öffentlichen
Niederspannungsnetz

Modell: UFR1001E

Bestimmungsgemäße Verwendung:

Selbsttätige Schaltstelle mit dreiphasiger Netzüberwachung gemäß ÖVE/ÖNORM E 8001-4-712, Anhang A für Photovoltaikanlagen mit einer Paralleleinspeisung über Wechselrichter in das Netz der öffentlichen Versorgung.

Prüfgrundlagen:

ÖVE/ÖNORM E 8001-4-712:2009-12, Anhang A
Errichtung von elektrischen Anlagen mit Nennspannungen bis AC 1000V und DC 1500V – Teil 4-712:
Photovoltaische Energieerzeugungsanlagen- Errichtungs- und Sicherheitsanforderungen

Ein repräsentatives Testmuster des oben genannten Erzeugnisses entspricht den zum Zeitpunkt der Ausstellung dieser Bescheinigung geltenden sicherheitstechnischen Anforderungen der aufgeführten Prüfgrundlagen für die bestimmungsgemäße Verwendung.

Bericht Nummer: 11TH0501-ÖNORM

Zertifikat Nummer: U13-0735

Datum: 2013-10-11

Gültig bis:

2016-10-10

Zertifizierungsstelle

Dieter Zitzmann



QUALITY



HEALTH



SAFETY



ENVIRONMENT



SOCIAL
RESPONSIBILITY



**BUREAU
VERITAS**

**Bureau Veritas
Consumer Products Services
Germany GmbH**
Businesspark A96
86842 Türkheim
Germany
+ 49 (0) 40 740 41 – 0
cps-tuerkheim@de.bureauveritas.com

Certification body of BV CPS GmbH
Accredited according to EN 45011 -
ISO / IEC Guide 65

Certificate of compliance

Applicant: ZIEHL industrie-elektronik GmbH+Co KG
Daimlerstraße 13
74523 Schwäbisch Hall
Germany

Product: Automatic disconnection device between a generator
and the public low-voltage grid

Model: UFR1001E

Use in accordance with regulations:

Automatic disconnection device with three-phase mains surveillance in accordance with Engineering Recommendation G59/3 for generation systems with a parallel coupling in the public mains supply. This serves as a replacement for the disconnection device with isolating function that can access the distribution network provider at any time.

Applied rules and standards:

Engineering Recommendation G59/3:2013

Recommendation for the Connection of Generating Plant to the Distribution Systems of licensed Distribution Network Operators.

DIN V VDE V 0126-1-1:2006-02 (Functional safety)

Automatic disconnection device between a generator and the public low-voltage grid

At the time of issue of this certificate the safety concept of an aforementioned representative product corresponds to the valid safety specifications for the specified use in accordance with regulations.

The aforementioned product does not provide direct current injection monitoring and residual current monitoring. Therefore these protection functions need to be installed externally if required.

Report number: 11TH0501-G59/3
Certificate number: U14-0009
Date of issue: 2014-01-09 **Valid until:** 2017-01-08

Certification body

Dieter Zitzmann



QUALITY



HEALTH



SAFETY



ENVIRONMENT



SOCIAL
ACCOUNTABILITY

18. Certificate of conformity GB G83/2, Pr 22+23



**BUREAU
VERITAS**

**Bureau Veritas
Consumer Products Services
Germany GmbH**
Businesspark A96
86842 Türkheim
Germany
+ 49 (0) 40 740 41 – 0
cps-tuerkheim@de.bureauveritas.com

Certification body of BV CPS GmbH
Accredited according to EN 45011 -
ISO / IEC Guide 65

Certificate of compliance

Applicant: ZIEHL industrie-elektronik GmbH+Co KG
Daimlerstraße 13
74523 Schwäbisch Hall
Germany

Product: Automatic disconnection device between a generator
and the public low-voltage grid

Model: UFR1001E

Use in accordance with regulations:

Automatic disconnection device with three-phase mains surveillance in accordance with Engineering Recommendation G83/2 for generation systems with a parallel coupling in the public mains supply. This serves as a replacement for the disconnection device with isolating function that can access the distribution network provider at any time.

Applied rules and standards:

Engineering Recommendation G83/2:2012

Recommendations for the Connection of Type Tested Small-scale Embedded Generators (Up to 16A per Phase) in Parallel with Low-Voltage Distribution Systems

DIN V VDE V 0126-1-1:2006-02 (Functional safety)

Automatic disconnection device between a generator and the public low-voltage grid

At the time of issue of this certificate the safety concept of an aforementioned representative product corresponds to the valid safety specifications for the specified use in accordance with regulations.

The aforementioned product does not provide direct current injection monitoring and residual current monitoring. Therefore these protection functions need to be installed externally if required.

Report number: 11TH0501-G83/2

Certificate number: U14-0008

Date of issue: 2014-01-09 **Valid until:** 2017-01-08

Certification body

Dieter Zitzmann



Deutsche
Akkreditierungsstelle
D-ZE-12024-01-01



QUALITY



HEALTH



SAFETY



ENVIRONMENT



SOCIAL
ACCOUNTABILITY



**BUREAU
VERITAS**

**Bureau Veritas
Consumer Products Services
Germany GmbH**

Businesspark A96
86842 Türkheim
Germany
+ 49 (0) 40 740 41 - 0
cps-tuerkheim@de.bureauveritas.com

Certification body of BV CPS GmbH
Accredited according to EN 45011 -
ISO / IEC Guide 65

Certificate of compliance

Applicant: ZIEHL industrie-elektronik GmbH+Co KG
Daimlerstraße 13
74523 Schwäbisch Hall
Germany

Product: Automatic disconnection device between a generator and
the public low-voltage grid

Model: UFR1001E

Use in accordance with regulations:

Automatic disconnection device with three-phase mains surveillance in accordance with DIN V VDE V 0126-1-1/A1:2012-02 for systems with a parallel coupling via an inverter in the public mains supply. This serves as a replacement for the disconnection device with insulating function which the distribution network provider can access at any time.

Applied rules and standards:

DIN V VDE V 0126-1-1 (VDE V 0126-1-1):2006-02
Automatic disconnection device between a generator and the public low-voltage grid

DIN V VDE V 0126-1-1/A1 (VDE V 0126-1-1/A1):2012-02
Automatic disconnection device between a generator and the public low-voltage grid; Amendment 1.

The safety concept of an aforementioned representative product corresponds at the time of issue of this certificate to the valid safety specifications for the specified use in accordance with regulations.

Report number: 11TH0501-VDE0126
Certificate number: U14-0064
Date of issue: 2014-02-04

Certification body

Dieter Zitzmann



Deutsche
Akkreditierungsstelle
D-ZE-12024-01-01



QUALITY



HEALTH



SAFETY



MANAGEMENT



SOCIAL
ACCOUNTABILITY



**BUREAU
VERITAS**

**Bureau Veritas
Consumer Products Services
Germany GmbH**

Businesspark A96
86842 Türkheim
Deutschland
+ 49 (0) 4074041-0
cps-tuerkheim@de.bureauveritas.com

Organisme de certification BV CPS GmbH
accrédité par EN 45011 -
ISO / IEC Guide 65

Certificat de conformité

Demandeur: ZIEHL industrie-elektronik GmbH+Co KG
Daimlerstraße 13
74523 Schwäbisch Hall
Allemagne

Produit: Dispositif de déconnexion automatique entre un
générateur et le réseau public à basse tension

Modèle: UFR1001E

À utiliser conformément aux réglementations:

Dispositif de coupure automatique avec une surveillance du réseau triphasé, conformément à DIN V VDE V 0126-1-1/A1:2012-02 VFR2013/VFR2014 (Protections des installations de production raccordées Identification au réseau public de distribution, ERDF-NOI-RES_13E, Version 5, 30/06/2013) pour des systèmes avec un couplage parallèle via un convertisseur à alimentation électrique publique. Il remplace l'appareil de déconnexion avec une fonction isolante, auquel le fournisseur du réseau de distribution peut accéder à tout moment.

Réglementations et normes appliquées:

DIN V VDE V 0126-1-1 (VDE V 0126-1-1):2006-02

Dispositif de déconnexion automatique entre un générateur et le réseau public à basse tension

DIN V VDE V 0126-1-1/A1 (VDE V 0126-1-1/A1):2012-02

Dispositif de déconnexion automatique entre un générateur et le réseau public à basse tension;
Amendement 1

ERDF-NOI-RES_13E:2013-06

Protections des installations de production raccordées Identification au réseau public de distribution,
ERDF-NOI-RES_13E, Version 5, 30/06/2013

Un échantillon représentatif des produits mentionnés ci-dessus correspond aux exigences de sécurité technique en vigueur à la date d'émission de ce certificat pour l'usage spécifié et conformément à la réglementation.

Numéro de rapport: 11TH0501-VDE0126

Numéro de certificat: U14-0063

Délivré le: 2014-02-04

Organisme de certification

Dieter Zitzmann



Deutsche
Akkreditierungsstelle
D-ZE-12024-01-01



QUALITY



HEALTH



SAFETY



ENVIRONMENT



SOCIAL
ACCOUNTABILITY

21. Adjustment values table VDE-AR-N 4105, Low Voltage Pr 1+2+7

Protective function	AR 4105	ZIEHL	in * Un	in % Un	Adjustment value	Tripping time dAL	OFF-delay time doF
Voltage decrease protection	U<	U ₋	0.8 * Un	80 % Un	184 V	100 ms	60 s
Voltage increase protection (10-minutes mean value)	U>	U _∞	1.1 * Un	110% Un	253V	100 ms	60 s
Voltage increase protection	U>>	U ⁻	1.15 * Un	115% Un	264V	100 ms	60 s
Frequency decrease protection	f<	F ₋			47.5Hz	100 ms	60 s
Frequency increase protection	f>	F ⁻			51.5Hz	100 ms	60 s

22. Adjustment values table BDEW June 2008, acc 3.2.3.3-1, Medium Voltage Pr 3-6

Function	Adjustment range of the protective relay	Default settings	
Voltage increase protection U>>	1.00 – 1.30 U _n	1.15 U _n	100 ms
Voltage increase protection U>	1.00 – 1.30 U _n	1.08 U _n	60 s
Voltage decrease protection U<	0.15 – 1.00 U _n	0.80 U _n	2.7 s
Voltage decrease protection U<< *	0.15 – 1.00 U _n	0.45 U _n	300 ms
Frequency increase protection f>	50.0 – 65.0 Hz	51.5Hz	100 ms
Frequency decrease protection f<	45.0 – 50.0 Hz	47.5Hz	100 ms
* Not enabled in as delivered condition			