

Operating instructions - Archive document -

Wireless temperature relay type WR250

potential-free temperature monitoring

- Integrated antenna
- Input for external antenna when mounted in shielded area (metallic switchgear cabinet) or under difficult radio reception conditions

ATTENTION: No external antenna included within the scope of supply.
Please order extra when required.



Table of Contents

1.	Application and brief description	3
2.	Function overview.....	3
3.	Connection diagram	3
4.	Display and control elements	4
5.	Important information	5
6.	Installation	6
7.	Detailed description	6
8.	Starting the wireless system.....	7
8.1	General notes on operation	7
8.2	Display mode	7
8.3	Menu mode	7
8.4	Parametrization mode	7
8.5	Operating flowchart	8
8.6	Startup overview.....	9
8.7	Configuration.....	9
8.8	Registration of wireless sensors.....	9
8.9	Alarm parametrization	10
8.10	Short-circuit monitoring	11
8.11	Relay test	11
8.12	RS485 Modbus interface.....	12
8.13	Sensor Simulation	12
8.14	Code lock	13
8.15	Notes on operation:	13
8.16	Device reaction time – measuring time t_M	14
8.17	Possible values in the display	14
9.	Factory default settings.....	16
10.	Servicing and maintenance.....	17
11.	Troubleshooting.....	17
11.1	Displaying the software version.....	18
12.	Technical data	18
13.	Design V4.....	20

1. Application and brief description

The WR250 wireless relay is a receiver and evaluation device for WS Pt 100 wireless sensors. Up to 6 wireless sensors transmit temperature values by radio, which are displayed and evaluated by the WR250.

Use:

- for overheating protection in high-voltage transformers (also in primary coils)
- for measuring temperatures at high potential
- where contact-free data transmission by radio is preferred

2. Function overview

- evaluation of 1 – 6 WS Pt 100 wireless sensors
- measurement and control range 0 ... 180°C
- 4 relay output ports (1 changeover contact each), 3 alarms fully programmable
- switch points and relay function pre-set for transformer control (ventilator, warning and shut-down)
- alarm in case of sensor errors at the «sensor alarm» relay
- multi-voltage power supply AC/DC 24-240 V
- display / store the measured MIN and MAX values
- interface RS485 (Modbus) for scanning of temperature and alarms and for parametrization
- Feeder clamps pluggable
- Intergrated antenna, input for external antenna

3. Connection diagram

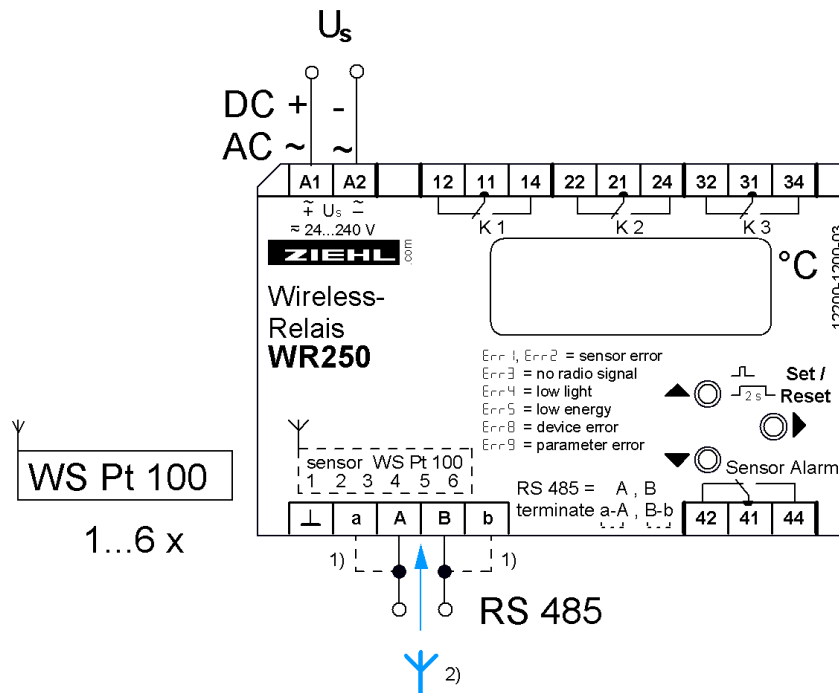

- 1) Links for terminating resistor
- 2) Connector for external antenna

4. Display and control elements

1 LEDs relay status

- K1, K2, K3 lit yellow = relay engaged
- sensor alarm (K4) lit red = relay disengaged

2 Digital display, 4 digits for

- temperature
- alarms (**AL1** , **AL2** , **AL3**)
- error messages (**Err1** ... **Err9**)
- menu and parameterization mode

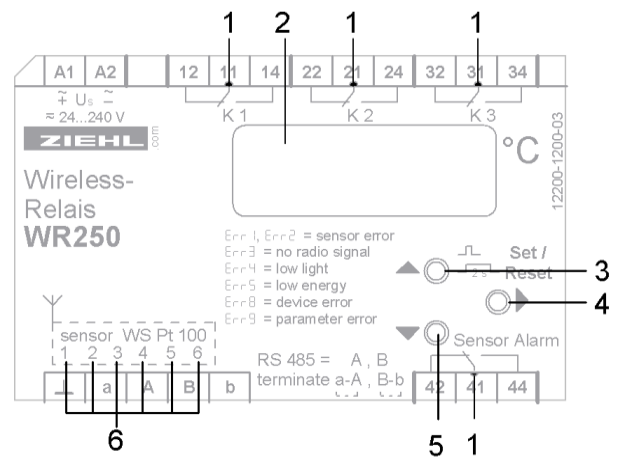

3 Key «Up» (in Display mode, normal state)

- Press briefly: Change to menu mode (see operating instructions item 8.3)
- Confirmation for > 2 s: Display MAX values measured by the selected sensor. Additional pressing of the «Set» key for ≥ 2s will erase the stored MIN/MAX values.

4 Key «Set/Reset» (in Display mode, normal state)

- Press briefly: Display the next sensor (sensor LED lit) / display the highest temperature measured by all sensors (LEDs for all registered sensors lit)
- Confirmation for 10 s: Display the software version (z. B. **0-00**)

5 Key «Down» (in Display mode, normal state)

- Press briefly: Change to Menu mode (see operating instructions item 8.3)
- Confirmation for > 2 s: Display the MIN value measured by the selected sensor. Additional pressing of the «Set» key for ≥ 2s will erase the stored MIN/MAX values.

6 Sensor LEDs

- Yellow LEDs on: indicate the wireless sensor currently displayed. If the LEDs for all registered sensors are lit, the warmest is being shown.
- Red LEDs on: indicate an error at the wireless sensor. The sensor can be selected using key «Set/Reset», and the display will show an Error Code (**Err**).

The following Error Codes are possible:

Err1	sensor short-circuited at the WS Pt 100 wireless sensor
Err2	sensor interruption at the WS Pt 100 wireless sensor
Err3	no radio contact with the WS Pt 100 wireless sensor
Err4	illumination of the WS Pt 100 wireless sensor too low
Err5	energy level of the WS Pt 100 wireless sensor too low

5. Important information



WARNUNG

**Dangerous electric voltage!
May cause electric shock and burns.
Before beginning work, disconnect system and device.**

Correct and safe operations of any device requires that it has been transported and stored appropriately, installed and commissioned correctly and is being operated according to the instructions.

Only persons familiar with installation, start-up and operations and possessing qualifications appropriate for their work may perform work on the device. They must observe the contents of the operating instructions, the information printed on the device and the relevant safety regulations for construction and operation of electric installations.

The devices are manufactured in accordance with DIN / EN and leave the production site in a condition of safety-related flawlessness.

If in any case the information provided in the operating instructions should be insufficient, please contact us directly, or address your local representative.

When using the device outside the area of applicability of the industrial norms referred to in the present operating instructions and valid in Europe, in their stead comply with the applicable regulations valid in the country of application.



Caution!

Do not connect or disconnect the device under power. Before connecting the device to the mains, make sure that the control voltage according to the type plate (on the side of the device) U_C matches the voltage of the grid which the device is to be connected to!



Caution!

If the «operating current» function is programmed for all relays, a failure of control voltage or of the system may remain undetected. When using the device for control, it is the operator's responsibility to detect this error by regular controls. We recommend to program at least one relay in the system for standby current and to evaluate it accordingly.

Caution! Multi-voltage power supply

The device is equipped with a multi-voltage power supply suitable for DC and AC power supply. Before connecting the device to the mains, make sure that the permissible control voltage range according to the type plate (on the side of the device) U_C matches the voltage of the grid which the device is to be connected to!

6. Installation

The device can be fastened:

- Distributor installation or switching cabinet on 35 mm mounting rail according to EN 60715
- Wall-mounting with M4 screws. (additional bar not included in delivery)

Connect in accordance with connection diagram or type plate.

Pay attention to the maximally permissible temperature when installing into a switching cabinet. Provide sufficient distance from other devices or heat sources. If cooling is hampered e. g. by close vicinity of devices with increased surface temperature or by obstruction of the cooling air flow, the permissible ambient temperature is reduced.

7. Detailed description

- The WR250 displays and evaluates the temperatures transmitted from the wireless sensors WS Pt 100.
- The hottest wireless sensor switches the relay.
- For the relays K1 (alarm 1), K2 (alarm 2) and K3 (alarm 3), the following can be selected individually:
 - alarm value
 - hysteresis
 - response and reset delay
 - operation current or standby current
 - cyclic relay test (e. g. K1 for ventilator)
 - alarm in case of error 3 (no radio contact with WS Pt 100)
- In case of an error at the WS Pt 100 wireless sensor, the relay will switch off the sensor alarm (K4), and the red LED is lit.
- In addition, the MIN and MAX temperature values of each WS Pt 100 wireless sensor are stored.
- The device can be polled remotely via a RS485 Modbus interface, and data can be queried.

Under difficult radio reception conditions or unfavorable mounting positions (e.g. shielded switchgear-cabinet) an external antenna can be connected.

For more informations concerning ranges and coverage see „APPLICATION NOTE AN001“ at www.enocean.de.

8. Starting the wireless system

8.1 General notes on operation

The decimal point behind the last 7-element display shows the operating mode which the device is in.

8.2 Display mode

Decimal point off (normal state for temperature display)

	Display current sensor temperature in °C (sensor LED lit)
	Display the highest temperature measured by all attached sensors (LEDs for all active sensors lit)
	Display errors at the wireless sensor with error code (only when displaying individual sensors), e. g. Err1 , Err2 , ...
	Display alarm messages (AL1 , AL2 or AL3)
LED yellow K 1, K 2 and K 3	AN («on») = relay engaged AUS («off») = relay disengaged
LED red sensor alarm	AN («on») = relay disengaged AUS («off») = relay engaged
LED Sensor WS Pt 100	yellow = temperature of the selected wireless sensor is being displayed. If the LEDs for all registered sensors are lit, the hottest is being shown. red = error in selected wireless sensor
function key «Set/Reset»	<u>Press briefly:</u> Display the next sensor (sensor LED lit) and display the highest temperature measured by all sensors (LEDs for all registered sensors lit) <u>Confirmation for 10 s:</u> Display the software version
function keys «Up» and «Down»	<u>Press briefly:</u> Change to Menu mode <u>Confirmation for ≥2 s:</u> Display MIN and MAX values measured by the selected sensor. Additional pressing of the «Set» key for ≥ 2s will erase the stored values.

8.3 Menu mode

Decimal point on

	Select the menu items for changing parameters
function keys «Up» and «Down»	<u>Press briefly:</u> Select menu item; change to Display mode
function keys «Set/Reset»	<u>Press briefly:</u> Change to Parametrization mode

8.4 Parametrization mode

Decimal point flashing

function key «Up» and «Down»	<u>Press briefly/for a longer time:</u> Change parameter value (slow/fast)
function keys «Set/Reset»	<u>Press briefly:</u> Accept setting and selection of the next parameter, after the last parameter change to Menu mode

Note: Press the «Set» key for 2 s to return to Display mode from Menu mode / Parametrization mode. The same thing happens if no key has been pressed for 30 s (Exception: 15 min in Simulation mode).

8.5 Operating flowchart

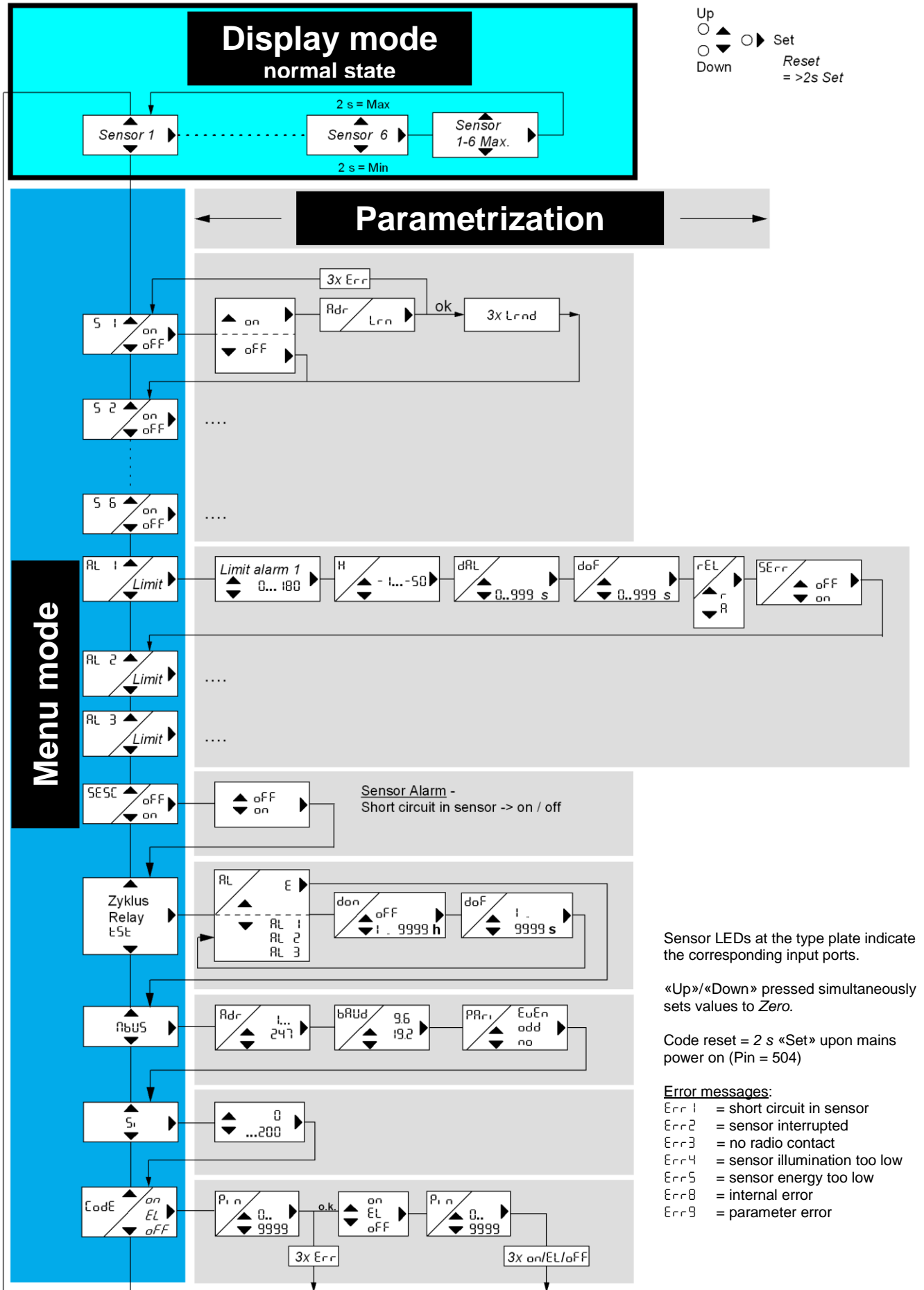

8.6 Startup overview

required	optional	Overview
X		8.7 configuration (basic settings of the device)
X		8.8 registration of wireless sensors WS Pt 100
X		8.9 alarm parametrization
	X	8.10 relay test
	X	8.11 sensor simulation
	X	8.12 RS485 Modbus interface
	X	8.13 code lock

8.7 Configuration

The appropriate program must be selected in accordance with the settings of the wireless sensors (see operating instructions for WS Pt 100 wireless sensors). This is done once during commissioning.

• switch of control voltage at the WR250
• keep «Set» key pressed and switch on control voltage again ⇒ after 10 s, Pr 5 is shown in the display
• release «Set» key
• select program in accordance with the wireless sensors, using the «Up»/«Down» keys (program # see operating instructions for WS Pt 100 wireless sensor)
• press «Set» key ⇒ device goes through reset and starts

8.8 Registration of wireless sensors

Start in Display mode (return to Display mode by pressing «Set» key for ≥ 2s). After 30 s without input, the device will also return to Display mode.

• press «Down» key ⇒ display 5 1 . / oFF . (sensor 1 / off) flashes alternatingly
• press «Set» key
• press «Down» key («Up» key turns off the sensor input port) ⇒ display on . (on)
• press «Set» key ⇒ display Rdr . / Lrn . (address / learn) flashes alternatingly
• within 30 s, briefly (approx. 1 s) link contacts 3 and 4 of the sensor plug-in socket at the WS Pt 100 wireless sensor (small wire jumper, or if the sensor plug is plugged in, briefly link the two contacts 3 and 4) ⇒ registration OK: Display Lrnd. (learned) will flash 4x ⇒ registration error: Display Err . (error) will flash 4x ⇒ display 5 2 . / oFF . (sensor 2 / off) flashes alternatingly
• register sensors 2 to 6 (optional)
• after sensor 6, change to next menu item (parametrization of alarms)

8.9 Alarm parametrization

The following parameters are important:

alarm value	AL 1. AL 2. AL 3.	limit values for the alarms. alarm 1 for relay K1, alarm 2 for relay K2 and alarm 3 for relay K3.
hysteresis	H .	reset value calculated from alarm value + hysteresis e. g.: 90°C (limit value) + (-5)°C (hysteresis) = 85°C (reset value)
alarm delay on	dAL .	alarm will be suppressed for the selected time (seconds)
alarm delay off	doF .	alarm will be switched off only after falling below limit (alarm value + hysteresis) and elapse of this time (seconds)
relay	rEL .	standby current r. : In OK state (= alarm value not reached), the relay is engaged, it will be disengaged when reaching the alarm value. <u>Advantage:</u> errors and failures generally result in alarm <u>Disadvantage:</u> alarm also when control voltage is switched off. Unfavourable e. g. in transformers, in particular if WR250 control voltage is provided by the transformer to be controlled
		operating current R. : In OK state, the relay is disengaged, it will be engaged upon reaching the alarm value. No alarm in case of switched-off control voltage and failures.
Sensor-Error	SErr.	on . alarm if there is no radio contact with the WS Pt 100 wireless sensor (Err3). off . no alarm in case of Err3

Selection:

use the «Up» and «Down» keys to select menu item until ...

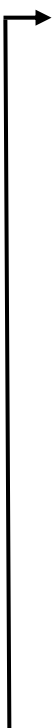
	⇒ display AL 1. / 90. (alarm 1 / limit value) flashes alternatingly
	• press «Set» key
	⇒ display 90. (current limit value, value may deviate)
	• use the «Up» and «Down» keys to select the desired limit value
	• press «Set» key
	⇒ display H . / -5. (hysteresis / value) flashes alternatingly
	• use the «Up» and «Down» keys to select the desired hysteresis
	• press «Set» key
	⇒ display dAL . / 0. (delay alarm / value) flashes alternatingly
	• use the «Up» and «Down» keys to select the desired value
	• press «Set» key
	⇒ display doF . / 0. (delay alarm off / value) flashes alternatingly
• use the «Up» and «Down» keys to select the desired value	
• press «Set» key	
⇒ display rEL . / r. (relay / Parameter) flashes alternatingly	
• use the «Up» and «Down» keys to select the desired value	
• press «Set» key	

⇒ display SErr. / oFF. (sensor error / value) flashes alternatingly
<ul style="list-style-type: none"> • use the «Up» and «Down» keys to select the desired value • press «Set» key
⇒ display AL 2. / 100. (alarm 2 / limit value) flashes alternatingly
⇒ parametrization of alarm 2 and alarm 3
<ul style="list-style-type: none"> • after parametrization of alarm 3, change to next menu item (RS485 Modbus)

8.10 Short-circuit monitoring

To avoid sensor-alarms at sensor-temperatures <0°C, short-circuit-monitoring can be de-activated. With short-circuit-monitoring de-activated, the WR250 will display -1°C at temperatures <0°C.

Selection:

use the «Up» and «Down» keys to select menu item until ...

<ul style="list-style-type: none"> • display SE5C. / oN. (short-circuit monitoring / on) flashes alternatingly
⇒ press «Set» key
<ul style="list-style-type: none"> • use the «Up» and «Down» keys to select the desired value
<ul style="list-style-type: none"> • display oN. (on/with) / oFF. (off/without)
⇒ press «Set» key (change to next menu item)

8.11 Relay test

Here you can define that after a specified time **don**, e. g. 2 weeks (= 336 hours), a relay will go to alarm state for a time of **doF**, e. g. 10 s. This may be required to shortly start a ventilator of a pump to move them and prevent damage to the bearings by long downtimes.

The following parameters are important:

Relay test	t5t.	relay test – Menu
alarm #	AL 1. AL 2. AL 3.	relay test alarm 1 (relay K1) relay test alarm 2 (relay K2) relay test alarm 3 (relay K3)
time of test	don.	shows after which time (in h) the relay test will be started or repeated, respectively
duration of test	doF.	shows how long (in s) the relay test will run

How to adjust:

Select menu item with «Up»/«Down» keys until ...

⇒ display shows t5t.
<ul style="list-style-type: none"> • press «Set» key
⇒ display AL . / E . (alarm / exit) flashes alternatingly
<ul style="list-style-type: none"> • Use the «Up» and «Down» keys to select the desired alarm # AL 1., AL 2., AL 3., or press E . (Exit) to leave the menu item • press «Set» key
⇒ display don. / oFF. (time of test / value) flashes alternatingly
<ul style="list-style-type: none"> • use the «Up» and «Down» keys to select the desired time for repetition of the relay test, oFF. – 1. – 999. h • press «Set» key

- use the «Up» and «Down» keys to select the duration of the relay test, **l.** – **999.** s
- press «Set» key

The elapsed test time **don** is stored persistently in the device.

8.12 RS485 Modbus interface

The following parameters are important:

Modbus	МБУ5.	Modbus menu
Address	Адр .	Address of device, selectable from range 1 to 247
baud rate	бАУд.	baud rate, 9600 or 19200
parity	РАРi .	parity : ЕУЕп. , odd . , пo . (even, odd, none)

Selection:

select menu item with «Up»/«Down» keys until ...

⇒ display МБУ5.
• press «Set» key
⇒ display Адр . / l. (address / value) flashes alternately
• use the «Up» and «Down» keys to select the desired address
• press «Set» key
⇒ display бАУд. / 96. (baud rate / value) flashes alternately
• use the «Up» and «Down» keys to select the desired baud rate
• press «Set» key
⇒ display РАРi . / ЕУЕп. (parity / value) flashes alternately
• use the «Up» and «Down» keys to select the desired value
• press «Set» key
⇒ leave menu item RS485 Modbus
⇒ change to next menu item (Sensor Simulation)

Further informations relating to Modbus configuration and programming can be found in Appendix 1 (available for download from www.ziehl.de).

8.13 Sensor Simulation

Here you can simulate a temperature. All functions of the device will work as if this temperature were actually measured.

If no key has been pressed for 15 minutes, the device automatically returns to Display mode.

Select menu item with keys «Up»/«Down» until ...

⇒ display 5i .
• press «Set» key
• use the «Up» and «Down» keys to select the desired temperature
• press «Set» key
⇒ leave menu item Simulation
⇒ change to next menu item (Code lock)

8.14 Code lock

Here you can protect the entered parameters by activating code lock.

The device will reject faulty input with **Err** (flashes 3x).

Select menu item with keys «Up»/«Down» until ...

⇒ display Cod . / oFF . (Code lock / off or on) flashes alternately
• press «Set» key
⇒ display Pin . / 0. (pin / pin code) flashes alternately
• use the «Up» and «Down» keys to select the stored pin code (factory default setting is 504.)
• press «Set» key
• use the «Up» and «Down» keys to select the desired code lock: <ul style="list-style-type: none"> ○ oFF . off, any parameter may be modified ○ EL . EasyLimit, only alarm values may be modified ○ on . on, no parameter may be modified
• press «Set» key
⇒ display Pin . / 504. (pin / pin code) flashes alternately
• use the «Up» and «Down» keys to enter the desired new pin code (Caution: write down pin code)
• press «Set» key
⇒ Code lock on, display on flashes 3x
⇒ Code lock EasyLimit, display EL flashes 3x
⇒ Code lock off, display oFF flashes 3x
⇒ leave menu item Code lock and change to Display mode (normal state).

8.15 Notes on operation:

- After completion of any program item, the program will continue with the next one.
- If the right decimal point of the 7-segment display is lit, you have left the Display mode and may select the individual menu items by pressing «Up»/«Down» (Menu mode).
- If the right decimal point flashes, you are in Parametrization mode and may change the settings by pressing «Up»/«Down».
- Pressing «Up»/«Down» for longer periods of time accelerates changes in the display.
- Pressing «Up»/«Down» simultaneously sets the selected values to zero.
- Reset (pressing «Set/Reset» for 2 s) will take you back to Display mode from any position in Parametrization mode or Menu mode (exception: Simulation), accepting the most recently entered value.

8.16 Device reaction time – measuring time t_M

The reaction time of the device depends on the measuring and transmission times of the wireless sensors (see operating instructions WS Pt 100 wireless sensor).

The wireless sensors measure the temperature every 1 s, 10 s or 100 s and transmit it to the WR250 after every single, after every 10th or after every 100th measurement. Consequently, there may be delays in sending and evaluating temperature changes. Temperature changes > 4 °C will be sent immediately after measurement.

The delay times d_{AL} and d_{oF} may be increased by the duration of the transmission intervals ($\pm 20\%$).

8.17 Possible values in the display

In Display mode (normal state)	
AL 1 / AL 2 / AL 3	alarm 1, alarm 2, alarm 3 active (relay function dependent on programming for standby or operating current)
Err 1	sensor short-circuited at the WS Pt 100 wireless sensor
Err 2	sensor interruption at the WS Pt 100 wireless sensor
Err 3	no radio contact with the WS Pt 100 wireless sensor
Err 4	illumination of the WS Pt 100 wireless sensor too low
Err 5	energy level of the WS Pt 100 wireless sensor too low
Err 8	WR250 internal error
Err 9	parameter error (illogic configuration of the WR250)

sensors, Menu mode / Parametrization mode	
S 1 ... S 2	sensors 1 to 6
on / oFF	sensors on / off
Adr / Lrn	flashes alternatingly, ready for registration of a new sensor
Lrnd	new sensor registered successfully (learned)

alarm values, Menu mode / Parametrization mode	
AL 1 / AL 2 / AL 3	alarm values
H	hysteresis
dAL	delay until alarm
dof	delay until alarm reset
rEL	relay function
r / R	relay function – standby current, operating current

Short-circuit monitoring, Menu mode / Parametrization mode	
SESC	Short-circuit monitoring
oFF / on	off (without) / on (with) Short-circuit monitoring

relay test, Menu mode / Parametrization mode	
EST	relay test
AL / E	alarm / exit
AL 1 / AL 2 / AL 3	relay test on alarm 1 (K1) / alarm 2 (K2) / alarm 3 (K3)
don	shows after which time (in h) the relay test will be started or repeated, respectively
doF	shows how long (in s) the relay test has been running

RS485 interface Modbus, Menu mode / Parametrization mode	
MBUS	Modbus (RS485 interface)
Adr	Modbus – device address
baud	Modbus – baud rate
9.6 / 19.2	Modbus – baud rate, 9600 or 19200
PAR1	Modbus – parity
Even / odd / no	Modbus – parity bit – even / odd / none

Simulation, Menu mode / Parametrization mode	
Si	Simulation

Code lock, Menu mode / Parametrization mode	
cod	Code lock
Pin	pin code
on / EL / off	Code lock on / EasyLimit / off

9. Factory default settings

When switching the program (operating instructions item «Configuration»), all parameters are reset to their factory default settings.

Menu mode	Parameter	Factory default settings	My data
sensor 1 .. 6	S 1	oFF	
	S 2	oFF	
	S 3	oFF	
	S 4	oFF	
	S 5	oFF	
	S 6	oFF	
alarm 1 relay K1	AL 1 limit	90 °C	
	H hysteresis	- 10 °C	
	dAL delay – alarm	0 s	
	doF delay – alarm off	999 s	
	rEL relay function	A	
	SErrr alarm sensor error 3	on	
alarm 2 relay K2	AL 2 limit	130 °C	
	H hysteresis	-5 °C	
	dAL delay – alarm	0 s	
	doF delay – alarm off	0 s	
	rEL relay function	r	
	SErrr alarm sensor error3	oFF	
alarm 3 relay K3	AL 3 limit	150 °C	
	H hysteresis	-5 °C	
	dAL delay – alarm	0 s	
	doF delay – alarm off	0 s	
	rEL relay function	A	
	SErrr alarm sensor error3	oFF	
SESC	SESC Short-circuit monitoring	on	
relay test tSt	AL 1 don Time of test	oFF	
	doF duration of test	1	
	AL 2 don Time of test	oFF	
	doF duration of test	1	
	AL 3 don Time of test	oFF	
	doF duration of test	1	
Modbus	Adr	1	
	bAUd	9.6	
	PARr	EUEr	
Cod	on / EL / oFF	oFF	
	Pi n	504	

10. Servicing and maintenance

ZIEHL industrie-elektronik GmbH + Co KG
Daimlerstr.13
D-74523 Schwäbisch Hall
Germany
Phone: +49 791 504-0
Fax: +49 791 504-56
Email: info@ziehl.de
Homepage: <http://www.ziehl.de>

11. Troubleshooting

Err1 or Err2 shown in the display	
cause	sensor short-circuited or sensor interrupted at the WS Pt 100 wireless sensor
remedy	please check temperature sensor at the WS Pt 100 wireless sensor for being electrically in order and correctly connected. (see operating instructions: WS Pt 100 wireless sensor)

Err3 shown in the display	
cause	no radio contact with the WS Pt 100 wireless sensor ⇒ distance from WS Pt 100 wireless sensor too great ⇒ storage capacitor in the WS Pt 100 wireless sensor exhaustively discharged
remedy	<ul style="list-style-type: none">• reduce distance between devices• charge storage capacitor, illuminate WS Pt 100 wireless sensor with > 1000 lux for approx. 2 – 3 hours

Err4 shown in the display	
cause	illumination of the WS Pt 100 wireless sensor too low or failed
remedy	provide illumination or increase light intensity, respectively

Err5 shown in the display	
cause	energy level of the WS Pt 100 wireless sensor too low
remedy	charge storage capacitor, illuminate WS Pt 100 wireless sensor with > 1000 lux for approx. 2 – 3 hours

Err8 shown in the display	
cause	WR250 internal error
remedy	send the device in for examination

Err9 shown in the display	
cause	Parameter error (implausible configuration of WR250)
remedy	check alarm parametrization

Device refuses programming	
cause	Code lock
remedy	<p>The code lock provides protection from unauthorized manipulations of the device. When code lock is activated, parameters cannot be changed. The pin can be selected by the user.</p> <p><u>pin code unknown? → perform code reset:</u></p> <ul style="list-style-type: none"> ▪ Upon activation of the control voltage, keep «Set» key pressed for 2 s ⇒ display changes to 8888 – cod – oFF – 8888 ⇒ release «Set» key ⇒ code lock is deactivated, pin code is «504»

No registration of a WS Pt 100 wireless sensor with the WR250 possible	
cause	<ul style="list-style-type: none"> • distance between wireless sensor and WR250 too great • wireless sensor power too low for work • wrong registration contacts linked at the wireless sensor or static linkage of the contact
remedy	<ul style="list-style-type: none"> • reduce distance between the devices • charge storage capacitor, illuminate WS Pt 100 wireless sensor with > 1000 lux for approx. 2 – 3 hours • link registration contacts at the wireless sensor only briefly (see operating instructions: WS Pt 100 wireless sensor)

11.1 Displaying the software version

In Display mode, press the «Set» key for 10 s

12. Technical data

control voltage U_C	AC/DC 24 – 240 V 0/50/60 Hz <3 W < 6 VA
limit values	DC 20.4 – 297 V AC 20 – 264 V
measurement range	0 ... 180°C
tolerance	± 4 K
input for external antenna	FME plug
frequency range	868 MHz
antennas:	
for metal surfaces (e.g.)	<ul style="list-style-type: none"> • MAR-C3G-2F (ZIEHL, Order-no. 101100) • Hirschmann MCA 1890 MH • Hirschmann MCA 1890 MP
for other surfaces (e.g.)	<ul style="list-style-type: none"> • Hirschmann MCA 1890 MP • HAMA MiniPlanar 38499
extension-cable for antenna	RG58 - FME bushing / plug
length	max. 15m

relay output port	4 × 1 changeover contact
switching voltage	max. AC 415 V
switching current	max. 5 A
switching capacity	max. 1250 VA (ohmic load) max. 120 W at DC 24 V
Nominal operation current I _E :	
AC15	I _e = 3 A U _e = AC 250 V
DC13	I _e = 2 A U _e = DC 24 V
	I _e = 0,2 A U _e = DC 125 V
	I _e = 0,1 A U _e = DC 250 V
Recommended backup fuse	T 3.15 A (gL)
service life of contacts mech.	3 × 10 ⁷ switching cycles
service life of contacts electr.	1 × 10 ⁵ switching cycles at AC 250 V / 6 A
<hr/>	
Test conditions	EN 50178 / EN 60 947
rated impulse withstand voltage	4000 V
degree of soiling	3
rated insulation voltage U _i	300 V
Uptime	100 %
permissible ambient temperature	-20 °C ... +60 °C EN 60068-2-2 dry heat
EMC – stability	EN 61000-6-2
EMC – interference emissions	EN 61000-6-3
vibration resistance EN 60068-2-6	2 ... 25 Hz ±1,6 mm 25 ... 150 Hz 5 g
<hr/>	
Casing	V4 design, distributor installation
installation depth	55 mm
width	4 TE
dimensions (B × H × T)	70 × 90 × 58 mm
line connector, single wire	1 × 1.5 mm ² each
finely stranded with wire end ferrule	1 × 1.0 mm ² each
Protection class, casing	IP 30
Protection class, clamps	IP 20
fastening	snap mounting on bearing rail 35 mm according to EN 60 715 or screw fastening M 4 (additional bar not included in delivery)
weight	approx. 190 g

Subject to technical modifications

13. Design V4

Dimensions in mm

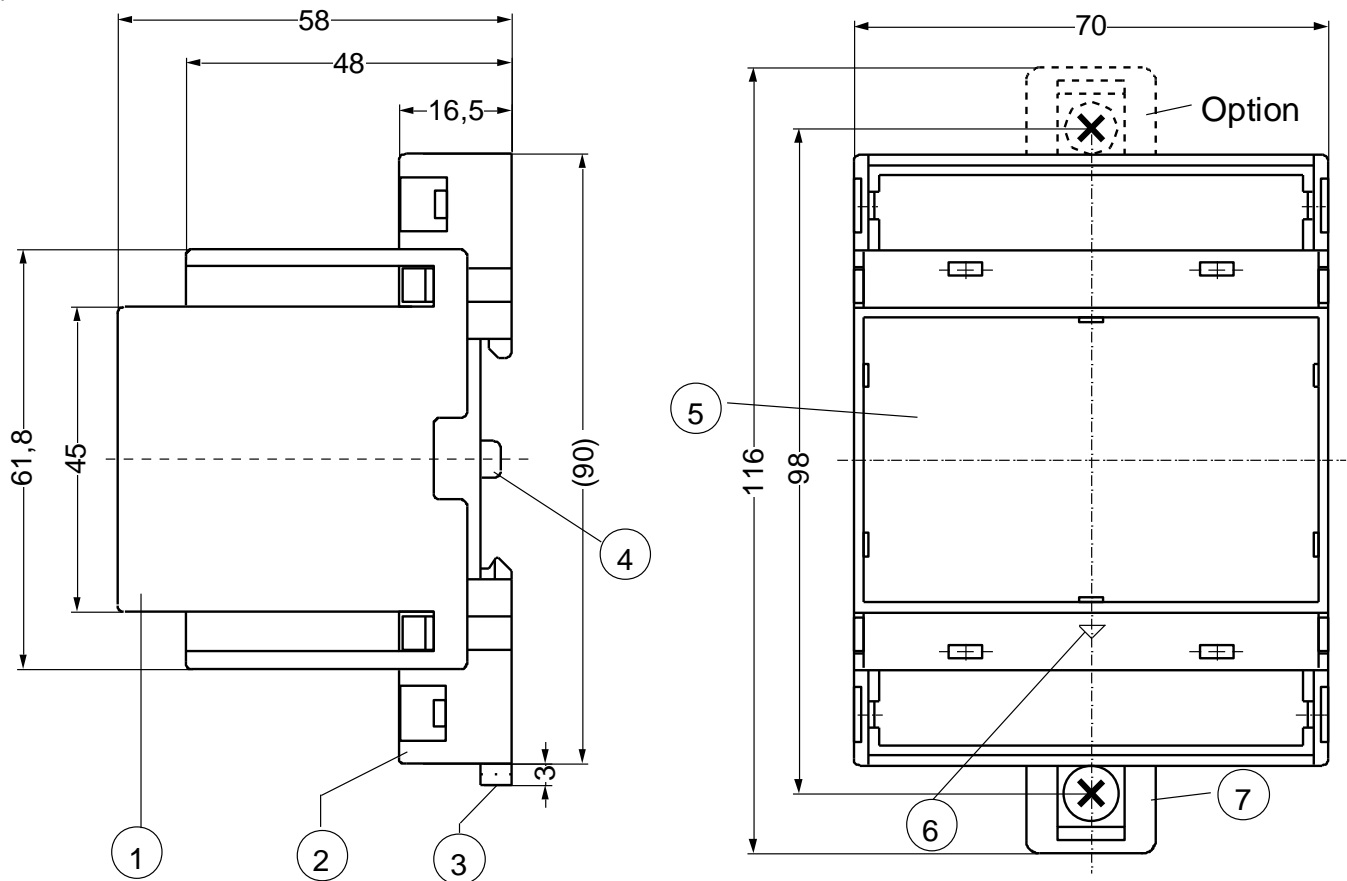

- 1 Oberteil / cover
- 2 Unterteil / base
- 3 Riegel / bar for snap mounting
- 4 Plombenlasche / latch for sealing
- 5 Frontplatteneinsatz / front panel
- 6 Kennzeichen für unten / position downward
- 7 Riegel bei Wandbefestigung mit Schrauben. Riegelbohrung \varnothing 4,2 mm / for fixing to wall with screws, \varnothing 4,2 mm

Sie finden diese und weitere Betriebsanleitungen, soweit verfügbar auch in englisch, auf unserer Homepage www.ziehl.de.

You find this and other operating-manuals on our homepage www.ziehl.de, as far as available also in English.