

AC-Electronic Current Transducer STWA4MH

AC 0 - 60 A, with interface RS485

STWA4MH

Electronic Current Transformer 0 - 60 A, with interface RS485

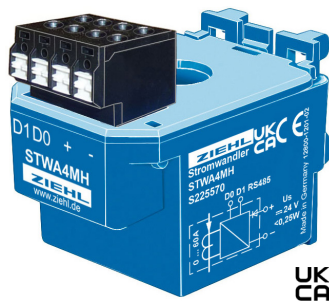

Part number: **S225570**

STWA4MH is a measuring transducer. It measures AC up to 60A and has an RS485 interface (Modbus RTU). The measured analog current value is made available as a digital signal and can be read by a PLC, an IPC or a master computer.

The conductor to be measured is passed through an opening (Ø 11 mm). In case of small currents, the sensitivity of the current transducer can be increased by looping through the current-carrying conductor several times, e.g. double looping doubles the sensitivity. The measuring range of the STWA4MH is reduced by multiple looping. To measure currents of any size, the STWA4MH is simply looped into the secondary circuit of a large current transformer with a secondary output of 5A (lead the cable through STWA4MH several times).

Rated supply voltage U_s DC 24 V, 10,0 ... 30,0 V, < 0,25 W
 Measuring input current AC 0 ... 60 A, sinus shaped (RMS)
 Error (from 1%/I_{nom}) 0,1 % ± 200 mA
 Temperature coefficient ± 0,1 %/K
 Resolution 1 mA
 Measurement time 1 period (40 ... 70 Hz)
 Overload constantly/10s I_{nom} + 20% / AC 200 A
 Measuring range frequency 40...70 Hz
 Error (from 1% I_{nom}) ≤ 0,1 Hz
 Resolution 0,01 Hz
 Rated insulation voltage 300 V
 Rated ambient temperature range -20 ... +55 °C

Housing/Dimensions (h x w x d) Design H: 50 x 36 x 56 mm
 Max. Ø conductor 11 mm
 Weight app. 90 g

Application:

The STWA4MH enables the space-saving and cost-effective measurement of the actual value of an alternating current. Compared to transducers with analog output, the bus technology significantly reduces the effort for the hardware (inputs) and the wiring. Applications are e.g. the recording of the current consumption of electrical motors in processing machines. Here the feed can be regulated depending on the load on the motor. Another example is the monitoring of consumers, e.g. heating elements, for failure.

- Current measurement AC 0...60 A (RMS - Root Mean Square), resolution 1mA
 - Actual value
 - Average over 200 ms
 - Average over 1 s
 - Measured values from the last 50 periods
- Frequency measurement 40...70 Hz (sinus-shaped signals)
- RS485 interface (Modbus RTU)
- Addressable up to 246 participants
- Baud rates 4800, 9600, 19200, 57600, 115200
- Wiring effort minimized through bus technology
- Supply voltage DC 24 V (10...30V)
- Connection via plug in spring type terminals
- Lockable housing on mounting rail or screw fastening
- Plug in current transformer (Ø 11 mm)

Dimension illustrations/ wiring sheme

Dimensions in mm

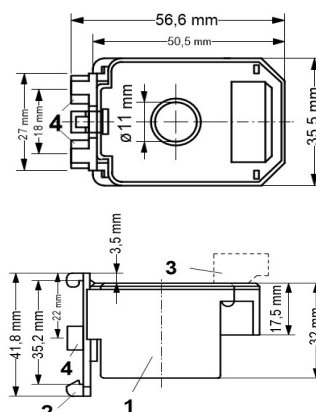

- 1 Housing
- 2 Clip for DIN-rail
- 3 Terminal (pluggable)
- 4 Wall-mounting (M4)

